

Bellows-Sealed Valves

BS1 Series



- ❖ Maximum working pressure up to 1000 psig (68.9 bar)
- ❖ Working temperature from -20°F to 900°F (-28°C to 482°C)
- ❖ Flow coefficients (Cv) from 0.12 to 1.2
- ❖ Variety of end connections
- ❖ 316 S.S., brass and monel 400 materials

Features

- ❖ Maximum working pressure up to 1000 psig (68.9 bar)
- ❖ Working temperature from -20°F to 900°F (-28°C to 482°C)
- ❖ Flow coefficients (Cv) from 0.12 to 1.2
- ❖ Variety of end connections
- ❖ 316 S.S., brass and monel 400 materials
- ❖ Panel and bottom mounting
- ❖ Bar, round handle are available
- ❖ Precision-formed metal bellows provides reliable seal
- ❖ Nonrotating stem tip: spherical, conical and regulating
- ❖ Gasket body to bellows seal is standard, weld seal also available
- ❖ Replaceable bellows and stem assembly
- ❖ Every valve is tested with helium for 10s to a maximum leak rate of 4×10^{-9} std cm³/s

Pressure-Temperature Ratings

Body Material	316 S.S.	Brass	Alloy 400
Temperature, °F(°C)	Working Pressure, psig(bar)		
-20 (-28) to 100 (37)	1000 (68.9)	1000 (68.9)	700 (48.2)
200 (93)	830 (57.1)	710 (48.9)	610 (42.0)
300 (148)	660 (45.4)	430 (29.6)	530 (36.5)
400 (204)	500 (34.4)	430 (29.6)	450 (31.0)
500 (260)	450 (31.0)	—	375 (25.8)
600 (315)	400 (27.5)	—	—

Flow Coefficient vs. Turns Open

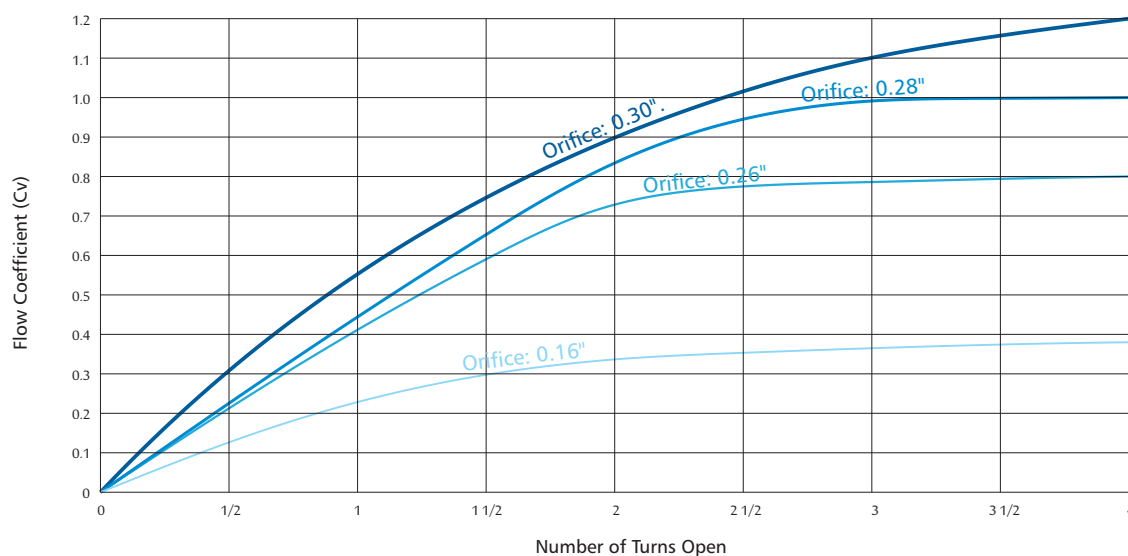

Standard Materials of Construction

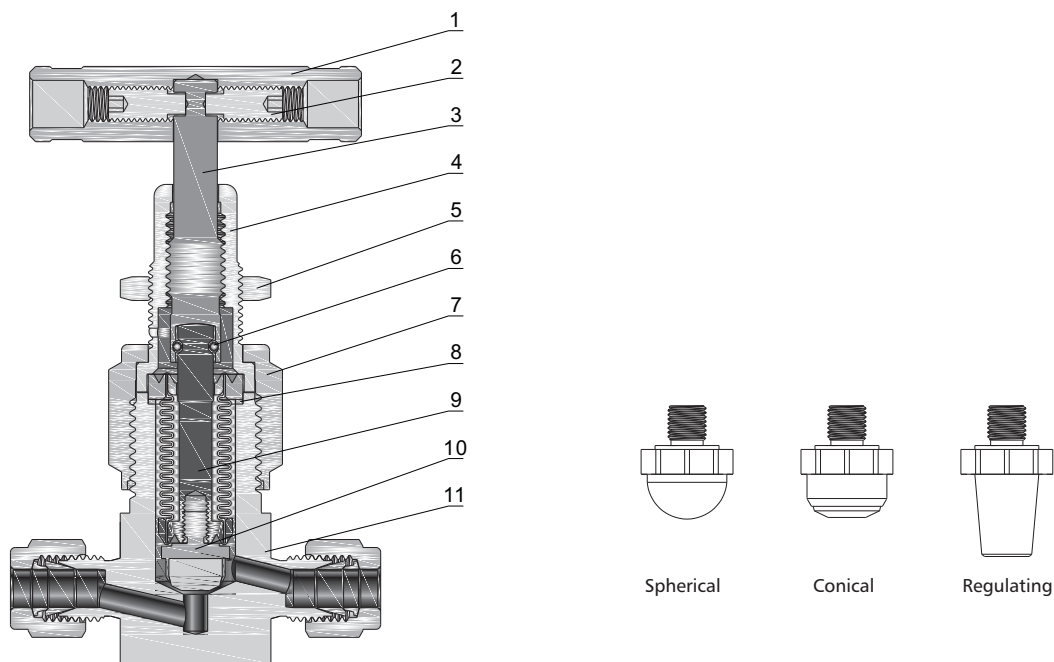

Component	Material Grade/ASTM Specification			
	316 S.S.	Brass	Alloy 400	
1	Handle	Anodized aluminum 2024-T4/B211		
2	Screw	Alloy Steel/ANSI 18.3		
3	Actuator	416 S.S./A582	416 S.S./A582	416 S.S./A582
4	Bonnet	316 S.S./A479	Brass/B16	316 S.S./A479
5	Nut	316 S.S./B783		
6	Pin	420 S.S.		
7	Bonnet Nut	Sliver-plated 316 S.S./A479	Slive-plated Brass/B16	Sliver-plated 316 S.S./A479
8	Gasket	Silver-plated 316 S.S./A580		Sliver-plated Alloy 400/AMS4730
		PTFE-coated 316 S.S./A580		PTFE-coated Alloy 400/AMS4730
9	Stem	316 S.S./A479		Alloy 400/B164
	Weld Ring	316 S.S./A479		Alloy 400/B164
	Bellows	316L S.S.		Alloy 400/B165
10	Stem Tip	316 S.S./A479 (regulating)		Alloy k-500/AMS4676 (regulating)
		PCTFE/D1430 (conical)		PCTFE/D1430 (conical)
		Weld Stellite (regulating or spherical)		—
11	Body	316 S.S./A479	Brass/B16	Alloy 400/B164

Dimensions

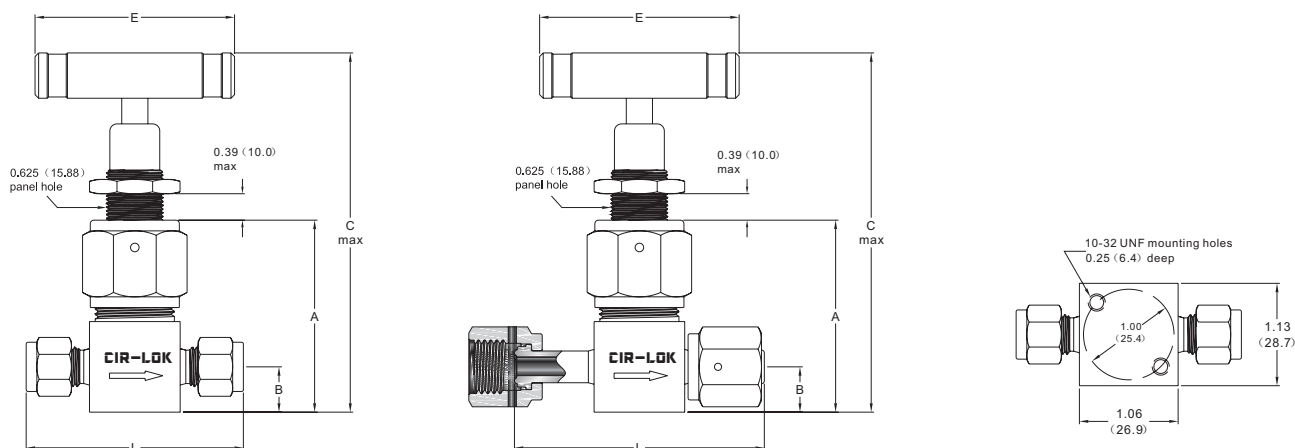

Basic Ordering Number	Connection Type and Size	Orifice in. (mm)	Cv	Dimension in. (mm)								
				A	B	C	D	E	L	W	H	Ød
BS1-F4-04-	1/4" CIR-LOK	0.16 (4.1)	0.36	2.12 (53.8)	0.5 (12.7)	4.01 (101.8)	0.39 (10.0)	2.20 (56.0)	2.46 (62.5)	1.00 (25.4)	1.06 (27.0)	1.00 (25.4)
BS1-F6-06-	3/8" CIR-LOK	0.26 (6.6)	0.80	2.12 (53.8)	0.5 (12.7)	4.01 (101.8)	0.39 (10.0)	2.52 (64.0)	3.09 (78.5)	1.00 (25.4)	1.57 (39.9)	1.00 (25.4)
BS1-F8-08-	1/2" CIR-LOK	0.30 (7.6)	1.20	2.24 (56.8)	0.56 (14.2)	4.13 (104.8)	0.39 (10.0)	2.52 (64.0)	3.30 (83.8)	1.13 (28.7)	1.57 (39.9)	1.13 (28.7)
BS1-M6-04-	6 mm CIR-LOK	0.16 (4.1)	0.36	2.12 (53.8)	0.5 (12.7)	4.01 (101.8)	0.39 (10.0)	2.20 (56.0)	2.46 (62.5)	1.00 (25.4)	1.06 (27.0)	1.00 (25.4)
BS1-M10-07-	10 mm CIR-LOK	0.28 (7.1)	1.00	2.24 (56.8)	0.56 (14.2)	4.13 (104.8)	0.39 (10.0)	2.52 (64.0)	3.11 (79.0)	1.13 (28.7)	1.57 (39.9)	1.13 (28.7)
BS1-M12-08-	12 mm CIR-LOK	0.30 (7.6)	1.20	2.24 (56.8)	0.56 (14.2)	4.13 (104.8)	0.39 (10.0)	2.52 (64.0)	3.30 (83.8)	1.13 (28.7)	1.57 (39.9)	1.13 (28.7)
BS1-FSW4-04-	1/4" FSW	0.16 (4.1)	0.36	2.12 (53.8)	0.5 (12.7)	4.01 (101.8)	0.39 (10.0)	2.20 (56.0)	1.68 (42.7)	1.00 (25.4)	1.00 (25.4)	1.00 (25.4)
BS1-FSW6-07-	3/8" FSW	0.28 (7.1)	1.00	2.12 (53.8)	0.5 (12.7)	4.01 (101.8)	0.39 (10.0)	2.20 (56.0)	2.27 (57.7)	1.00 (25.4)	1.06 (27.0)	1.00 (25.4)
BS1-FSW8-08-	1/2" FSW	0.30 (7.6)	1.20	2.12 (53.8)	0.5 (12.7)	4.01 (101.8)	0.39 (10.0)	2.20 (56.0)	2.27 (57.7)	1.00 (25.4)	1.06 (27.0)	1.00 (25.4)
BS1-FBW4-04-	1/4" FBW	0.16 (4.1)	0.36	2.12 (53.8)	0.5 (12.7)	4.01 (101.8)	0.39 (10.0)	2.20 (56.0)	1.68 (42.7)	1.00 (25.4)	1.00 (25.4)	1.00 (25.4)
BS1-FBW6-07-	3/8" FBW	0.28 (7.1)	1.00	2.12 (53.8)	0.5 (12.7)	4.01 (101.8)	0.39 (10.0)	2.20 (56.0)	2.18 (55.4)	1.00 (25.4)	1.06 (27.0)	1.00 (25.4)
BS1-FBW8-08-	1/2" FBW	0.30 (7.6)	1.20	2.12 (53.8)	0.5 (12.7)	4.01 (101.8)	0.39 (10.0)	2.20 (56.0)	2.18 (55.4)	1.00 (25.4)	1.06 (27.0)	1.00 (25.4)
BS1-FGFS4-04-	1/4" Female GFS	0.16 (4.1)	0.36	2.12 (53.8)	0.5 (12.7)	4.01 (101.8)	0.39 (10.0)	2.52 (64.0)	2.76 (70.1)	1.00 (25.4)	1.00 (25.4)	1.00 (25.4)
BS1-FGFS8-08-	1/2" Female GFS	0.30 (7.6)	1.20	2.24 (56.8)	0.56 (14.2)	4.13 (104.8)	0.39 (10.0)	2.52 (64.0)	3.12 (79.2)	1.13 (28.7)	1.50 (38.1)	1.13 (28.7)
BS1-GFS4-04-	1/4" Male GFS	0.16 (4.1)	0.36	2.12 (53.8)	0.5 (12.7)	4.01 (101.8)	0.39 (10.0)	2.20 (56.0)	2.24 (56.9)	1.00 (25.4)	1.00 (25.4)	1.00 (25.4)
BS1-GFS8-08-	1/2" Male GFS	0.30 (7.6)	1.20	2.24 (56.8)	0.56 (14.2)	4.13 (104.8)	0.39 (10.0)	2.52 (64.0)	3.00 (76.2)	1.13 (28.7)	1.50 (38.1)	1.13 (28.7)

How to Order

BS1 — **MBW10** — **M10** — **07** — **KR** — **G** — **316**

Series	Inlet Type	Inlet Size	Outlet Type	Outlet Size	Orifice Size	Tip Material	Tip Type	Handle	Body Material
BS1	FBW Fractional Tube Butt Weld	2 1/8 in.	Same as inlet type and inlet size		04 0.16 in. (4.1 mm)	Same as Body Material	Spherical	Blue Aluminum	316 316 S.S.
	MBW Metric Tube Butt Weld	4 1/4 in.			06 0.26 in. (6.6 mm)				
	F Fractional Tube Fitting	6 3/8 in. or 6 mm	If outlet and inlet are the same, eliminate the outlet designator	07 0.28 in. (7.1 mm)	S 304 Stainless Steel	304L 304L S.S.			
	M Metric Tube Fitting	8 1/2 in. or 8 mm		08 0.3 in. (7.6 mm)					
	UGF Nut+Gasket+Fractional Bulge Nipple	10 10 mm	12 3/4 in. or 12 mm	11 0.433 in. (11 mm)	K Black Knob				
	UGM Nut+Gasket+Metric Bulge Nipple			15 0.591 in. (15 mm)					
	FGFS Female GFS Fitting			20 0.787 in. (20 mm)					
	GFS Male GFS Fitting								