

Pipe Fittings

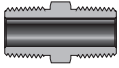

Contents

Hex Nipples



04

Close Nipples



07

Special Pipe Nipples

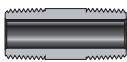

07

Hex Long Nipples



08

Hex Couplings



09

Reducing Bushings



10

Pipe Plugs



12

Hollow Hex Plugs



13

Pipe Caps



14

Adapters



15

Male Elbows



17

Street Elbows



18

45° Street Elbows

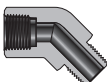

20

Female Elbows



22

45° Female Elbows

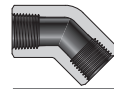

23

Male Tees



24

Female Branch Tees

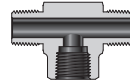

25

Female Run Tees

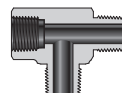

25

Male Street Tees

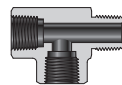

26

Male Branch Tees



27

Female Tees

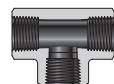

28

Female Crosses

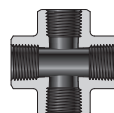

29

Pipe to Pipe Unions

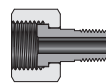

29

Union Ball Joints



30

Male Pipe to Tube Butt Weld

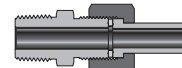

30

Features

- ❖ Available in sizes from 1/16 to 2 in. and 6 mm to 30 mm
- ❖ CIR-LOK pipe Fittings materials include stainless steel, alloy 400/R-405, brass, and carbon steel
- ❖ CIR-LOK provide NPT, ISO/BSP, SAE and ISO threads configurations
- ❖ Burrfree smooth thread provide optimum sealing and minimize galling

Materials Standards

Material	Bar Stock	Forgings
316 stainless steel	ASTM A276 ASME SA479, EN 1.4401	ASTM A182 ASME SA182, EN 1.4401
Alloy 20	ASTM B473	ASTM B462
Alloy 400/R-405	ASTM B164, ASME SB164	ASTM B564, ASME SB564
Alloy 600	ASTM B166, ASME SB166	ASTM B564, ASME SB564
Alloy 625	ASTM B446	ASTM B564, ASME SB564
Alloy 825	ASTM B425	ASTM B564, ASME SB564
Alloy C-276	ASTM B574	ASTM B564
Aluminum	ASTM B211	ASTM B247
Brass	ASTM B16, ASTM	ASTM B283
Carbon steel	B453 ASTM A108	—

Thread Specifications

Thread Type(End Connection)	Reference Specification
NPT	ASME B1.20.1, SAE AS71051
ISO/BSP(parallel) (Based on DIN 3852) (CIR-LOK PPT,BP,and BS fittings)	ISO 228,JIS B0202
ISO/BSP(tapered) (Based on DIN 3852) (CIR-LOK BT fittings)	ISO 7,BS EN 10226-1, JIS B0203
ISO/BSP(gauge) (Based on EN 837-1 and 837-3) (CIR-LOK BG)	ISO 228
Unified (SAE) (CIR-LOK SA fittings)	ASME B1.1

Working Temperature Rating

Material	Working Temperature Rating °F(°C)
316 stainless steel	-65(-53) to 1000 (537)
Brass	-20(-28) to 400 (204)
Carbon steel	-65(-53) to 375 (190)
BS gaskets(FKM)	-5(-15) to 400 (204)
BG BP gaskets (copper)	-5(-15) to 400 (204)
SAE O-ring (FKM)	-5(-15) to 400 (204)

Hex Nipples

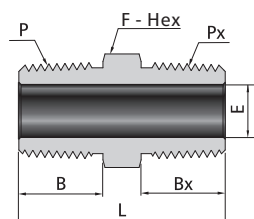

Male NPT Threads

P-NPT Size	Px-NPT Size	Basic Ordering Number	Dimension, mm					Working Pressure psig (bar)	
			L	F	B	Bx	E	316 SS, Steel	Brass
1/16	1/16	NPT1-THN-NPT1-	25.6	7.9	9.7	9.7	3.0	11000 (757)	5500 (378)
1/8	1/16	NPT2-THN-NPT1-	25.6	11.1	9.7	9.7	3.0	11000 (757)	5500 (378)
1/8	1/8	NPT2-THN-NPT2-	25.6	11.1	9.7	9.7	4.8	10000 (689)	5000 (344)
1/4	1/16	NPT4-THN-NPT1-	31.0	14.3	14.2	9.7	3.0	11000 (757)	5500 (378)
1/4	1/8	NPT4-THN-NPT2-	31.0	14.3	14.2	9.7	4.8	10000 (689)	5000 (344)
1/4	1/4	NPT4-THN-NPT4-	35.6	14.3	14.2	14.2	7.1	8000 (551)	4000 (275)
3/8	1/16	NPT6-THN-NPT1-	31.8	17.5	14.2	9.7	3.0	11000 (757)	5500 (378)
3/8	1/8	NPT6-THN-NPT2-	31.8	17.5	14.2	9.7	4.8	10000 (689)	5000 (344)
3/8	1/4	NPT6-THN-NPT4-	36.3	17.5	14.2	14.2	7.1	8000 (551)	4000 (275)
3/8	3/8	NPT6-THN-NPT6-	36.3	17.5	14.2	14.2	9.7	7800 (537)	3900 (268)
1/2	1/8	NPT8-THN-NPT2-	37.3	22.2	19.1	9.7	4.8	7700 (530)	3800 (261)
1/2	1/4	NPT8-THN-NPT4-	41.9	22.2	19.1	14.2	7.1	8000 (551)	4000 (275)
1/2	3/8	NPT8-THN-NPT6-	41.9	22.2	19.1	14.2	9.7	7800 (537)	3900 (268)
1/2	1/2	NPT8-THN-NPT8-	46.7	22.2	19.1	19.1	11.9	7700 (530)	3800 (261)
3/4	1/8	NPT12-THN-NPT2-	40.4	27.0	19.1	9.7	4.8	10000 (689)	5000 (344)
3/4	1/4	NPT12-THN-NPT4-	41.9	27.0	19.1	14.2	7.1	8000 (551)	4000 (275)
3/4	3/8	NPT12-THN-NPT6-	45.2	27.0	19.1	14.2	9.7	7800 (537)	3900 (268)
3/4	1/2	NPT12-THN-NPT8-	46.7	27.0	19.1	19.1	11.9	7700 (530)	3800 (261)
3/4	3/4	NPT12-THN-NPT12-	46.7	27.0	19.1	19.1	15.7	7300 (502)	3600 (248)
1	1/8	NPT16-THN-NPT2-	45.2	34.9	23.9	9.7	4.8	10000 (689)	5000 (344)
1	1/4	NPT16-THN-NPT4-	49.3	34.9	23.9	14.2	7.1	5300 (365)	2600 (179)
1	3/8	NPT16-THN-NPT6-	50.0	34.9	23.9	14.2	9.7	7800 (537)	3900 (268)
1	1/2	NPT16-THN-NPT8-	54.1	34.9	23.9	19.1	11.9	7700 (530)	3800 (261)
1	3/4	NPT16-THN-NPT12-	54.1	34.9	23.9	19.1	15.7	7300 (502)	3600 (248)
1	1	NPT16-THN-NPT16-	58.9	34.9	23.9	23.9	22.4	5300 (365)	2600 (179)
1 1/4	1	NPT20-THN-NPT16-	62.2	44.5	23.9	23.9	22.4	5300 (365)	2600 (179)
1 1/4	1 1/4	NPT20-THN-NPT20-	62.9	44.5	23.9	23.9	28.6	6000 (410)	3000 (200)
1 1/2	1 1/2	NPT24-THN-NPT24-	66.3	50.8	26.2	26.2	34.0	5000 (344)	2500 (172)
2	2	NPT32-THN-NPT32-	77.7	69.9	26.2	26.2	45.0	3900 (268)	1900 (130)

Heavy-Wall Male NPT Threads

1/4	1/4	NPT4-THN1-NPT4-	35.6	14.3	14.2	14.2	5.8	10000 (689)	/
1/2	1/4	NPT8-THN1-NPT4-	41.9	22.2	19.1	14.2	5.8	10000 (689)	/
1/2	1/2	NPT8-THN1-NPT8-	46.7	22.2	19.1	19.1	9.9	10000 (689)	/

Male ISO Tapered Threads

P-BSPT Size	Px-BSPT Size	Basic Ordering Number	Dimension, mm					Working Pressure psig (bar)	
			L	F	B	Bx	E	316 SS, Steel	Brass
1/8	1/8	MBT2-THN-MBT2-	25.6	11.1	9.7	9.7	4.8	10000 (689)	5000 (344)
1/4	1/4	MBT4-THN-MBT4-	35.6	14.3	14.2	14.2	7.1	8000 (551)	4000 (275)
3/8	3/8	MBT6-THN-MBT6-	36.3	17.5	14.2	14.2	9.7	7800 (537)	3900 (268)
1/2	1/2	MBT8-THN-MBT8-	46.7	22.2	19.1	19.1	11.9	7700 (530)	3800 (261)
3/4	3/4	MBT12-THN-MBT12-	46.7	27.0	19.1	19.1	15.7	7300 (502)	3600 (248)
1	1	MBT16-THN-MBT16-	58.9	34.9	23.9	23.9	22.4	5300 (365)	2600 (179)

Hex Nipples

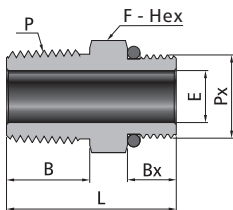
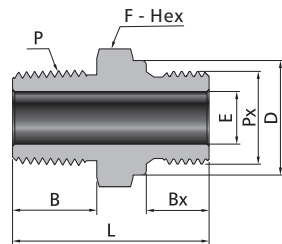
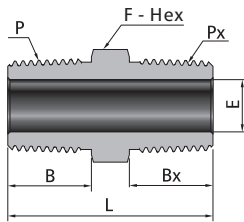

Male NPT Threads

P-NPT Size	Px-BSPT Size	Basic Ordering Number	Dimension, mm					Working Pressure psig (bar)	
			L	F	B	Bx	E	316 SS, Steel	Brass
1/8	1/8	NPT2-THN-MBT2-	25.6	11.1	9.7	9.7	4.8	10000 (689)	5000 (344)
1/4	1/4	NPT4-THN-MBT4-	35.6	14.3	14.2	14.2	7.1	8000 (551)	4000 (275)
3/8	3/8	NPT6-THN-MBT6-	36.3	17.5	14.2	14.2	9.7	7800 (537)	3900 (268)
1/2	1/2	NPT8-THN-MBT8-	46.7	22.2	19.1	19.1	11.9	7700 (530)	3800 (261)
3/4	3/4	NPT12-THN-MBT12-	46.7	27.0	19.1	19.1	15.7	7300 (502)	3600 (248)
1	1	NPT16-THN-MBT16-	58.9	34.9	23.9	23.9	22.4	5300 (365)	2600 (179)

Male ISO Tapered Threads

Male NPT Threads

P-NPT Size	Px-BS Size	Basic Ordering Number	Dimension, mm						Working Pressure psig (bar)	
			L	F	B	Bx	E	D	316 SS, Steel	Brass
1/8	1/8	NPT2-THN-MBS2-	27.7	14.3	9.7	7.1	4.1	13.7	11400 (785)	5700 (392)
1/4	1/4	NPT4-THN-MBS4-	36.8	19.1	14.2	11.2	5.8	18.0	10300 (709)	5100 (351)
3/8	3/8	NPT6-THN-MBS6-	37.6	22.2	14.2	11.2	7.9	21.6	10300 (709)	5100 (351)
1/2	1/2	NPT8-THN-MBS8-	44.4	27.0	19.1	14.2	11.9	25.9	7600 (523)	3800 (261)
3/4	3/4	NPT12-THN-MBS12-	49.0	33.3	19.1	15.7	15.7	32.0	7300 (502)	3600 (248)
1	1	NPT16-THN-MBS16-	56.6	41.3	23.9	18.3	19.8	38.9	7400 (509)	3700 (254)

Male ISO parallel Threads

Male NPT Threads

P-NPT Size	Px-SAE/MS Thread Size	Basic Ordering Number	Dimension, mm					Working Pressure psig (bar) 316 SS, Steel
			L	F	B	Bx	E	
1/4	7/16-20	NPT4-THN-OST7-	30.5	14.3	14.2	9.1	5.1	4500 (310)
3/8	9/16-18	NPT6-THN-OST9-	32.0	17.5	14.2	9.1	7.1	4500 (310)
1/2	3/4-16	NPT8-THN-OST12-	38.9	22.2	19.1	11.2	10.7	4500 (310)
3/4	1 1/16-12	NPT12-THN-OST17-	44.4	31.8	19.1	15.0	15.7	3600 (248)
1	1 5/16-12	NPT16-THN-OST21-	50.8	38.1	23.9	15.0	22.4	2900 (199)

Male SAE/MS Straight Threads

Hex Nipples

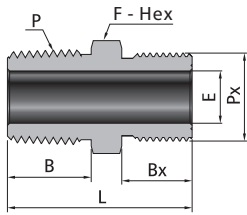

Male NPT Threads

Male Metric Threads

P-NPT Size	Px-Metric Size	Basic Ordering Number	Dimension, mm					Working Pressure psig (bar) 316 SS, Steel
			L	F	B	Bx	E	
1/8	M20 x 1.5	NPT2-THN-MS20-	32.7	22.2	9.7	16	5.0	7700 (530)
1/4	M8 x 1	NPT4-THN-MS8-	29.0	14.3	14.2	9	3.2	8000 (551)
1/4	M14 x 1.5	NPT4-THN-MS14-	34.2	15.9	14.2	13	7.0	8000 (551)
1/4	M16 x 1.5	NPT4-THN-MS16-	35.2	17.5	14.2	14	7.1	7800 (537)
1/4	M20 x 1.5	NPT4-THN-MS20-	37.2	22.2	14.2	16	7.0	7700 (530)
3/8	M14 x 1.5	NPT6-THN-MS14-	34.2	17.5	14.2	13	7.0	7800 (537)
3/8	M20 x 1.5	NPT6-THN-MS20-	37.2	22.2	14.2	16	9.5	7700 (530)
3/8	M24 x 1.5	NPT6-THN-MS24-	38.2	27	14.2	17	9.5	7400 (509)
1/2	M14 x 1.5	NPT8-THN-MS14-	39.1	22.2	19.1	13	7.0	7700 (530)
1/2	M20 x 1.5	NPT8-THN-MS20-	42.0	22.2	19.1	16	10.0	7700 (530)
1/2	M24 x 1.5	NPT8-THN-MS24-	43.5	27	19.1	17	11.9	7400 (509)
3/4	M20 x 1.5	NPT12-THN-MS20-	42.1	27	19.1	16	10.0	7300 (502)
3/4	M27 x 2	NPT12-THN-MS27-	46.7	31.8	19.1	18	15.8	6100 (420)
1	M30 x 2	NPT16-THN-MS30-	55.0	34.9	23.9	20	11.9	6100 (420)

Male ISO Tapered Threads

Male Metric Threads

P-BSPT Size	Px-Metric Size	Basic Ordering Number	Dimension, mm					Working Pressure psig (bar) 316 SS, Steel
			L	F	B	Bx	E	
1/8	M20 x 1.5	MBT2-THN-MS20-	32.7	22.2	9.7	16	5.0	7700 (530)
1/4	M12 x 1.5	MBT4-THN-MS12-	33.4	14.3	14.2	15	5.0	8000 (551)
1/4	M20 x 1.5	MBT4-THN-MS20-	37.2	22.2	14.2	16	7.0	7700 (530)
3/8	M20 x 1.5	MBT6-THN-MS20-	37.2	22.2	14.2	16	9.5	7700 (530)
1/2	M20 x 1.5	MBT8-THN-MS20-	42.0	22.2	19.1	16	10.0	7700 (530)

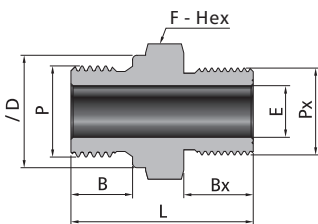

Male ISO Parallel Threads

Male Metric Threads

P-BS Size	Px-Metric Size	Basic Ordering Number	Dimension, mm					Working Pressure psig (bar) 316 SS, Steel	
			L	F	B	Bx	E		D
1/8	M20 x 1.5	MBS2-THN-MS20-	30.1	22.2	7.1	16	4.0	13.7	7700 (530)
1/4	M18 x 1.5	MBS4-THN-MS18-	34.2	20.6	11.2	15	5.9	18.0	7800 (537)
1/4	M20 x 1.5	MBS4-THN-MS20-	36.2	22.2	11.2	16	5.9	18.0	7700 (530)
3/8	M20 x 1.5	MBS6-THN-MS20-	36.2	22.2	11.2	16	7.9	21.6	7700 (530)
1/2	M20 x 1.5	MBS8-THN-MS20-	40.2	22.2	14.0	16	11.9	25.9	7700 (530)

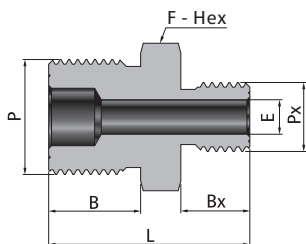

Male Metric Threads

P-Metric Size	Px-Metric Size	Basic Ordering Number	Dimension, mm					Working Pressure psig (bar) 316 SS, Steel
			L	F	B	Bx	E	
M20 x 1.5	M10 x 1	MS20-THN-MS10-	34	22.2	16	11	4.0	10000 (689)
M20 x 1.5	M12 x 1.5	MS20-THN-MS12-	35	22.2	16	12	6.0	9000 (620)
M20 x 1.5	M14 x 1.5	MS20-THN-MS14-	36	22.2	16	13	8.0	8000 (551)
M20 x 1.5	M16 x 1.5	MS20-THN-MS16-	37	22.2	16	14	9.0	7800 (537)
M20 x 1.5	M20 x 1.5	MS20-THN-MS20-	39	22.2	16	16	10.0	7700 (530)
M27 x 2	M27 x 2	MS27-THN-MS27-	44.5	30.1	18	18	14.0	7300 (502)

Close Nipples

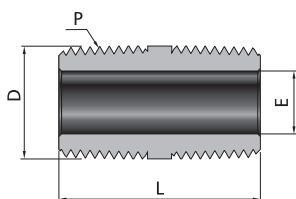

Male NPT Threads

P-NPT Size	Basic Ordering Number	Dimension, mm			Working Pressure psig (bar)	
		L	D	E	316 SS, Steel	Brass
1/16	NPT1-TCN-NPT1-	19.1	7.9	3.0	11000 (757)	5500 (378)
1/8	NPT2-TCN-NPT2-	19.1	10.3	4.8	10000 (689)	5000 (344)
1/4	NPT4-TCN-NPT4-	28.4	13.7	7.1	8000 (551)	4000 (275)
3/8	NPT6-TCN-NPT6-	28.4	17.1	9.6	7800 (537)	3900 (268)
1/2	NPT8-TCN-NPT8-	38.1	21.3	11.9	7700 (530)	3800 (261)
3/4	NPT12-TCN-NPT12-	38.1	26.7	15.7	7300 (502)	3600 (248)
1	NPT16-TCN-NPT16-	47.8	33.4	22.4	5300 (365)	2600 (179)

Male ISO Tapered Threads

P-BSPT Size	Basic Ordering Number	Dimension, mm			Working Pressure psig (bar)	
		L	D	E	316 SS, Steel	Brass
1/16	MBT1-TCN-MBT1-	19.1	7.9	3.0	11000 (757)	5500 (378)
1/8	MBT2-TCN-MBT2-	19.1	10.3	4.8	10000 (689)	5000 (344)
1/4	MBT4-TCN-MBT4-	28.4	13.7	7.1	8000 (551)	4000 (275)
3/8	MBT6-TCN-MBT6-	28.4	17.1	9.7	7800 (537)	3900 (268)
1/2	MBT8-TCN-MBT8-	38.1	21.3	11.9	7700 (530)	3800 (261)
3/4	MBT12-TCN-MBT12-	38.1	26.7	15.7	7300 (502)	3600 (248)
1	MBT16-TCN-MBT16-	47.8	33.4	22.4	5300 (365)	2600 (179)

Special Pipe Nipples

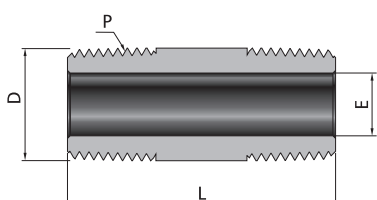

Male NPT Threads

P-NPT Size	Basic Ordering Number	Dimension, mm			Working Pressure psig (bar)	
		L	D	E	316 SS, Steel	Brass
1/8	NPT2-TPN-NPT2-38.1-	38.1	10.3	4.8	10000 (689)	5000 (344)
1/8	NPT2-TPN-NPT2-50.8-	50.8	10.3	4.8	10000 (689)	5000 (344)
1/8	NPT2-TPN-NPT2-63.5-	63.5	10.3	4.8	10000 (689)	5000 (344)
1/8	NPT2-TPN-NPT2-76.2-	76.2	10.3	4.8	10000 (689)	5000 (344)
1/4	NPT4-TPN-NPT4-38.1-	38.1	13.7	7.1	8000 (551)	4000 (275)
1/4	NPT4-TPN-NPT4-50.8-	50.8	13.7	7.1	8000 (551)	4000 (275)
1/4	NPT4-TPN-NPT4-63.5-	63.5	13.7	7.1	8000 (551)	4000 (275)
1/4	NPT4-TPN-NPT4-76.2-	76.2	13.7	7.1	8000 (551)	4000 (275)
1/4	NPT4-TPN-NPT4-101.6-	101.6	13.7	7.1	8000 (551)	4000 (275)
3/8	NPT6-TPN-NPT6-38.1-	38.1	17.1	9.7	7800 (537)	3900 (268)
3/8	NPT6-TPN-NPT6-50.8-	50.8	17.1	9.7	7800 (537)	3900 (268)
3/8	NPT6-TPN-NPT6-63.5-	63.5	17.1	9.7	7800 (537)	3900 (268)
3/8	NPT6-TPN-NPT6-76.2-	76.2	17.1	9.7	7800 (537)	3900 (268)
3/8	NPT6-TPN-NPT6-101.6-	101.6	17.1	9.7	7800 (537)	3900 (268)
1/2	NPT8-TPN-NPT8-50.8-	50.8	21.3	11.9	7700 (530)	3800 (261)
1/2	NPT8-TPN-NPT8-76.2-	76.2	21.3	11.9	7700 (530)	3800 (261)
1/2	NPT8-TPN-NPT8-101.6-	101.6	21.3	11.9	7700 (530)	3800 (261)
1/2	NPT8-TPN-NPT8-152.4-	152.4	21.3	11.9	7700 (530)	3800 (261)
3/4	NPT12-TPN-NPT12-50.8-	50.8	26.7	15.7	7300 (502)	3600 (248)
3/4	NPT12-TPN-NPT12-76.2-	76.2	26.7	15.7	7300 (502)	3600 (248)
3/4	NPT12-TPN-NPT12-101.6-	101.6	26.7	15.7	7300 (502)	3600 (248)
1	NPT16-TPN-NPT16-76.2-	76.2	33.4	22.4	5300 (365)	2600 (179)
1	NPT16-TPN-NPT16-101.6-	101.6	33.4	22.4	5300 (365)	2600 (179)

Hex Long Nipples

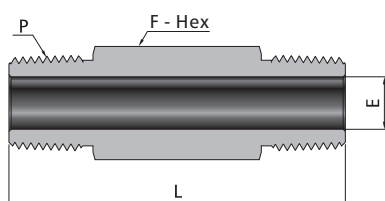

Male NPT Threads

P-NPT Size	Basic Ordering Number	Dimension, mm			Working Pressure psig (bar)	
		L	F	E	316 SS, Steel	Brass
1/8	NPT2-TLN-NPT2-38.1-	38.1	11.1	4.8	10000 (689)	5000 (344)
1/8	NPT2-TLN-NPT2-50.8-	50.8	11.1	4.8	10000 (689)	5000 (344)
1/8	NPT2-TLN-NPT2-63.5-	63.5	11.1	4.8	10000 (689)	5000 (344)
1/8	NPT2-TLN-NPT2-76.2-	76.2	11.1	4.8	10000 (689)	5000 (344)
1/4	NPT4-TLN-NPT4-38.1-	38.1	14.3	7.1	8000 (551)	4000 (275)
1/4	NPT4-TLN-NPT4-50.8-	50.8	14.3	7.1	8000 (551)	4000 (275)
1/4	NPT4-TLN-NPT4-63.5-	63.5	14.3	7.1	8000 (551)	4000 (275)
1/4	NPT4-TLN-NPT4-76.2-	76.2	14.3	7.1	8000 (551)	4000 (275)
1/4	NPT4-TLN-NPT4-101.6-	101.6	14.3	7.1	8000 (551)	4000 (275)
3/8	NPT6-TLN-NPT6-38.1-	38.1	17.5	9.7	7800 (537)	3900 (268)
3/8	NPT6-TLN-NPT6-50.8-	50.8	17.5	9.7	7800 (537)	3900 (268)
3/8	NPT6-TLN-NPT6-63.5-	63.5	17.5	9.7	7800 (537)	3900 (268)
3/8	NPT6-TLN-NPT6-76.2-	76.2	17.5	9.7	7800 (537)	3900 (268)
3/8	NPT6-TLN-NPT6-101.6-	101.6	17.5	9.7	7800 (537)	3900 (268)
1/2	NPT8-TLN-NPT8-50.8-	50.8	22.2	11.9	7700 (530)	3800 (261)
1/2	NPT8-TLN-NPT8-76.2-	76.2	22.2	11.9	7700 (530)	3800 (261)
1/2	NPT8-TLN-NPT8-101.6-	101.6	22.2	11.9	7700 (530)	3800 (261)
1/2	NPT8-TLN-NPT8-152.4-	152.4	22.2	11.9	7700 (530)	3800 (261)
3/4	NPT12-TLN-NPT12-50.8-	50.8	27.0	15.7	7300 (502)	3600 (248)
3/4	NPT12-TLN-NPT12-76.2-	76.2	27.0	15.7	7300 (502)	3600 (248)
3/4	NPT12-TLN-NPT12-101.6-	101.6	27.0	15.7	7300 (502)	3600 (248)
1	NPT16-TLN-NPT16-76.2-	76.2	34.9	22.4	5300 (365)	2600 (179)
1	NPT16-TLN-NPT16-101.6-	101.6	34.9	22.4	5300 (365)	2600 (179)

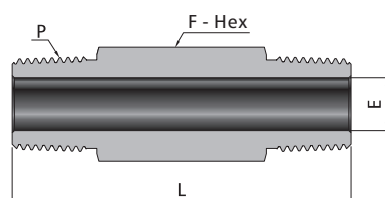

Male ISO Tapered Threads

P-BSPT Size	Basic Ordering Number	Dimension, mm			Working Pressure psig (bar)	
		L	F	E	316 SS, Steel	Brass
1/8	MBT2-TLN-MBT2-38.1-	38.1	11.1	4.8	10000 (689)	5000 (344)
1/8	MBT2-TLN-MBT2-50.8-	50.8	11.1	4.8	10000 (689)	5000 (344)
1/8	MBT2-TLN-MBT2-63.5-	63.5	11.1	4.8	10000 (689)	5000 (344)
1/8	MBT2-TLN-MBT2-76.2-	76.2	11.1	4.8	10000 (689)	5000 (344)
1/4	MBT4-TLN-MBT4-38.1-	38.1	14.3	7.1	8000 (551)	4000 (275)
1/4	MBT4-TLN-MBT4-50.8-	50.8	14.3	7.1	8000 (551)	4000 (275)
1/4	MBT4-TLN-MBT4-63.5-	63.5	14.3	7.1	8000 (551)	4000 (275)
1/4	MBT4-TLN-MBT4-76.2-	76.2	14.3	7.1	8000 (551)	4000 (275)
1/4	MBT4-TLN-MBT4-101.6-	101.6	14.3	7.1	8000 (551)	4000 (275)
3/8	MBT6-TLN-MBT6-38.1-	38.1	17.5	9.7	7800 (537)	3900 (268)
3/8	MBT6-TLN-MBT6-50.8-	50.8	17.5	9.7	7800 (537)	3900 (268)
3/8	MBT6-TLN-MBT6-63.5-	63.5	17.5	9.7	7800 (537)	3900 (268)
3/8	MBT6-TLN-MBT6-76.2-	76.2	17.5	9.7	7800 (537)	3900 (268)
3/8	MBT6-TLN-MBT6-101.6-	101.6	17.5	9.7	7800 (537)	3900 (268)
1/2	MBT8-TLN-MBT8-50.8-	50.8	22.2	11.9	7700 (530)	3800 (261)
1/2	MBT8-TLN-MBT8-76.2-	76.2	22.2	11.9	7700 (530)	3800 (261)
1/2	MBT8-TLN-MBT8-101.6-	101.6	22.2	11.9	7700 (530)	3800 (261)
1/2	MBT8-TLN-MBT8-152.4-	152.4	22.2	11.9	7700 (530)	3800 (261)
3/4	MBT12-TLN-MBT12-50.8-	50.8	27.0	15.7	7300 (502)	3600 (248)
3/4	MBT12-TLN-MBT12-76.2-	76.2	27.0	15.7	7300 (502)	3600 (248)
3/4	MBT12-TLN-MBT12-101.6-	101.6	27.0	15.7	7300 (502)	3600 (248)
1	MBT16-TLN-MBT16-76.2-	76.2	34.9	22.4	5300 (365)	2600 (179)
1	MBT16-TLN-MBT16-101.6-	101.6	34.9	22.4	5300 (365)	2600 (179)

Hex Couplings

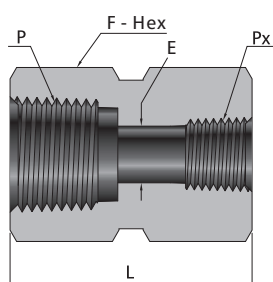

Female FNPT Threads

P-NPT Size	Px-NPT Size	Basic Ordering Number	Dimension, mm			Working Pressure psig (bar)	
			L	F	E	316 SS, Steel	Brass
1/16	1/16	FNPT1-THC-FNPT1-	19.8	11.1	4.8	6700 (460)	3300 (227)
1/8	1/8	FNPT2-THC-FNPT2-	20.6	14.3	8.6	6500 (447)	3200 (220)
1/4	1/8	FNPT4-THC-FNPT2-	31.0	19.1	8.6	6600 (454)	3300 (227)
1/4	1/4	FNPT4-THC-FNPT4-	30.2	19.1	11.4	6600 (454)	3300 (227)
3/8	1/4	FNPT6-THC-FNPT4-	35.1	22.2	11.4	5300 (365)	2600 (179)
3/8	3/8	FNPT6-THC-FNPT6-	33.3	22.2	15.0	5300 (365)	2600 (179)
1/2	1/8	FNPT8-THC-FNPT2-	39.6	27.0	8.6	4900 (337)	2400 (165)
1/2	1/4	FNPT8-THC-FNPT4-	44.4	27.0	11.4	4900 (337)	2400 (165)
1/2	3/8	FNPT8-THC-FNPT6-	45.2	27.0	15.0	4900 (337)	2400 (165)
1/2	1/2	FNPT8-THC-FNPT8-	39.6	27.0	18.5	4900 (337)	2400 (165)
3/4	1/4	FNPT12-THC-FNPT4-	46.0	33.3	11.4	4600 (316)	2300 (158)
3/4	1/2	FNPT12-THC-FNPT8-	52.3	33.3	18.5	4600 (316)	2300 (158)
3/4	3/4	FNPT12-THC-FNPT12-	41.1	33.3	23.9	4600 (316)	2300 (158)
1	1/2	FNPT16-THC-FNPT8-	55.6	41.3	18.5	4400 (303)	2200 (151)
1	3/4	FNPT16-THC-FNPT12-	57.2	41.3	23.9	4400 (303)	2200 (151)
1	1	FNPT16-THC-FNPT16-	50.8	41.3	29.7	4400 (303)	2200 (151)

Heavy-Wall Female FNPT Threads

1/4	1/4	FNPT4-THC1-FNPT4-	30.2	25.4	11.4	10000 (689)	/
1/2	1/2	FNPT8-THC1-FNPT8-	39.6	38.1	18.5	10000 (689)	/
1/2	1/4	FNPT8-THC1-FNPT4-	44.4	38.1	11.4	10000 (689)	/

Female ISO Tapered Threads

P-BSPT Size	Px-BSPT Size	Basic Ordering Number	Dimension, mm			Working Pressure psig (bar)	
			L	F	E	316 SS, Steel	Brass
1/8	1/8	FBT2-THC-FBT2-	20.6	14.3	8.4	6500 (447)	3200 (220)
1/4	1/4	FBT4-THC-FBT4-	30.2	19.1	11.2	6600 (454)	3300 (227)
3/8	1/4	FBT6-THC-FBT4-	35.1	22.2	11.2	5300 (365)	2600 (179)
3/8	3/8	FBT6-THC-FBT6-	33.3	22.2	14.7	5300 (365)	2600 (179)
1/2	1/4	FBT8-THC-FBT4-	44.4	27.0	11.2	4900 (337)	2400 (165)
1/2	3/8	FBT8-THC-FBT6-	45.2	27.0	14.7	4900 (337)	2400 (165)
1/2	1/2	FBT8-THC-FBT8-	39.6	27.0	18.3	4900 (337)	2400 (165)

Reducing Bushings

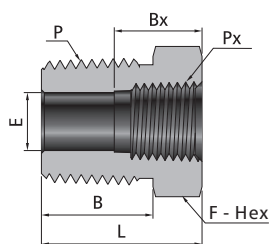

Male NPT Threads

Female NPT Threads

P-NPT Size	Px-NPT Size	Basic Ordering Number	Dimension, mm					Working Pressure psig (bar)	
			L	F	B	Bx	E	316 SS, Steel	Brass
1/8	1/16	NPT2-TRB-FNPT1-	26.2	11.1	9.7	9.9	4.8	6500 (447)	3200 (220)
1/4	1/16	NPT4-TRB-FNPT1-	21.8	14.3	14.2	9.9	4.8	8000 (551)	4000 (275)
1/4	1/8	NPT4-TRB-FNPT2-	26.9	14.3	14.2	10.4	7.1	6500 (447)	3300 (227)
3/8	1/16	NPT6-TRB-FNPT1-	21.8	17.5	14.2	9.9	4.8	13300 (971)	6600 (454)
3/8	1/8	NPT6-TRB-FNPT2-	21.8	17.5	14.2	10.4	8.6	9200 (633)	4700 (323)
3/8	1/4	NPT6-TRB-FNPT4-	30.2	19.1	14.2	15.0	9.6	6600 (454)	3300 (227)
1/2	1/8	NPT8-TRB-FNPT2-	27.4	22.2	19.1	10.4	8.6	12200 (840)	6200 (427)
1/2	1/4	NPT8-TRB-FNPT4-	27.4	22.2	19.1	15.0	11.4	8300 (571)	4400 (303)
1/2	3/8	NPT8-TRB-FNPT6-	35.8	22.2	19.1	15.0	11.9	5300 (365)	2600 (179)
3/4	1/8	NPT12-TRB-FNPT2-	27.4	27.0	19.1	10.4	7.1	20000(1378)	10000(689)
3/4	1/4	NPT12-TRB-FNPT4-	27.4	27.0	19.1	15.0	11.4	12000 (826)	6000 (410)
3/4	3/8	NPT12-TRB-FNPT6-	27.4	27.0	19.1	15.0	15.0	8200 (564)	4300 (296)
3/4	1/2	NPT12-TRB-FNPT8-	41.4	27.0	19.1	19.8	15.7	4900 (337)	2400 (165)
1	1/8	NPT16-TRB-FNPT2-	34.5	34.9	23.9	10.4	7.1	20000(1378)	10000(689)
1	1/4	NPT16-TRB-FNPT4-	34.8	34.9	23.9	15.0	11.4	14500 (999)	7400 (509)
1	3/8	NPT16-TRB-FNPT6-	34.8	34.9	23.9	15.0	15.0	11600 (799)	5900 (406)
1	1/2	NPT16-TRB-FNPT8-	34.8	34.9	23.9	19.8	18.5	8600 (592)	4300 (296)
1	3/4	NPT16-TRB-FNPT12-	47.0	34.9	23.9	20.6	22.4	5300 (365)	2600 (179)
1 1/4	3/4	NPT20-TRB-FNPT12-	37.3	44.5	23.9	20.6	22.4	7800 (537)	3900 (268)
1 1/4	1	NPT20-TRB-FNPT16-	37.3	44.5	23.9	25.4	22.4	3500 (241)	1750 (120)
1 1/2	1	NPT24-TRB-FNPT16-	40.1	50.8	26.2	25.4	22.4	6600 (454)	3300 (227)
1 1/2	1 1/4	NPT24-TRB-FNPT20-	56.0	54.0	26.2	25.4	34.0	5000 (344)	2500 (172)

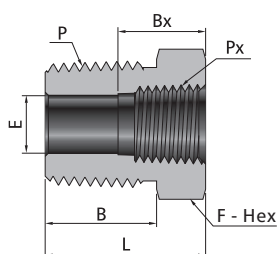

Male NPT Threads

Female ISO Tapered Pipe Threads

P-NPT Size	Px-BSPT Size	Basic Ordering Number	Dimension, mm					Working Pressure psig (bar)	
			L	F	B	Bx	E	316 SS, Steel	Brass
1/8	1/16	NPT2-TRB-FBT1-	26.2	11.1	9.7	9.9	4.8	6500 (447)	3200 (220)
1/4	1/16	NPT4-TRB-FBT1-	21.8	14.3	14.2	9.9	4.8	8000 (551)	4000 (275)
1/4	1/8	NPT4-TRB-FBT2-	26.9	14.3	14.2	10.4	7.1	6500 (447)	3300 (227)
3/8	1/16	NPT6-TRB-FBT1-	21.8	17.5	14.2	9.9	4.8	13300 (917)	6600 (454)
3/8	1/8	NPT6-TRB-FBT2-	21.8	17.5	14.2	10.4	7.1	9200 (633)	4700 (323)
3/8	1/4	NPT6-TRB-FBT4-	30.2	19.1	14.2	15.0	9.7	6600 (454)	3300 (227)
1/2	1/8	NPT8-TRB-FBT2-	27.4	22.2	19.1	10.4	7.1	12200 (840)	6200 (427)
1/2	1/4	NPT8-TRB-FBT4-	27.4	22.2	19.1	15.0	10.4	8300 (571)	4400 (303)
1/2	3/8	NPT8-TRB-FBT6-	35.8	22.2	19.1	15.0	11.9	5300 (365)	2600 (179)
3/4	1/8	NPT12-TRB-FBT2-	27.4	27.0	19.1	10.4	7.1	20000 (1378)	10000 (689)
3/4	1/4	NPT12-TRB-FBT4-	27.4	27.0	19.1	15.0	10.4	12000 (826)	6000 (410)
3/4	3/8	NPT12-TRB-FBT6-	27.4	27.0	19.1	15.0	12.7	8200 (564)	4300 (296)
3/4	1/2	NPT12-TRB-FBT8-	41.4	27.0	19.1	19.8	15.7	4900 (337)	2400 (165)
1	1/8	NPT16-TRB-FBT2-	34.5	34.9	23.9	10.4	7.1	20000 (1378)	10000 (689)
1	1/4	NPT16-TRB-FBT4-	34.8	34.9	23.9	15.0	10.4	14500 (999)	7400 (509)
1	3/8	NPT16-TRB-FBT6-	34.8	34.9	23.9	15.0	12.7	11600 (799)	5900 (406)
1	1/2	NPT16-TRB-FBT8-	34.8	34.9	23.9	19.8	15.7	8600 (592)	4300 (296)
1	3/4	NPT16-TRB-FBT12-	47.0	34.9	23.9	20.6	22.4	5300 (365)	2600 (179)
1 1/4	3/4	NPT20-TRB-FBT12-	37.3	44.5	23.9	20.6	22.4	7800 (537)	3900 (268)
1 1/4	1	NPT20-TRB-FBT16-	37.3	44.5	23.9	25.4	22.4	3500 (241)	1750 (120)
1 1/2	1	NPT24-TRB-FBT16-	40.1	50.8	26.2	25.4	22.4	6600 (454)	3300 (227)
1 1/2	1 1/4	NPT24-TRB-FBT20-	56.0	54.0	26.2	25.4	34.0	5000 (344)	2500 (172)

Reducing Bushings

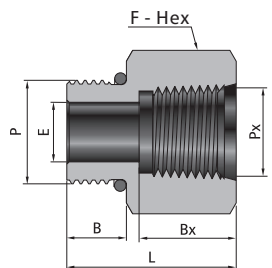
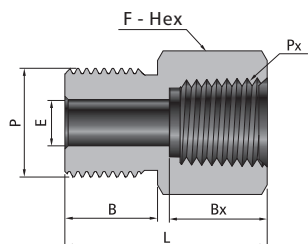
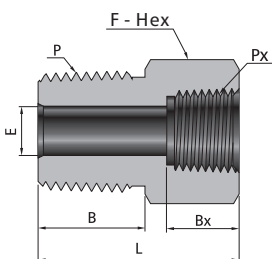
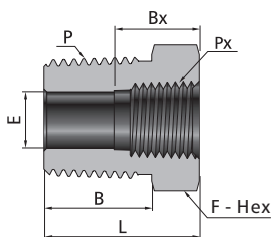

Male ISO Tapered Threads

Female ISO Tapered Threads

P-BSPT Size	Px-BSPT Size	Basic Ordering Number	Dimension, mm					Working Pressure psig (bar)	
			L	F	B	Bx	E	316 SS, Steel	Brass
1/4	1/8	MBT4-TRB-FBT2-	26.9	14.3	14.2	10.4	7.1	6500 (447)	3200 (220)
3/8	1/4	MBT6-TRB-FBT4-	30.2	19.1	14.2	15.0	9.6	6600 (454)	3300 (227)
1/2	1/4	MBT8-TRB-FBT4-	27.4	22.2	19.1	15.0	11.2	8300 (571)	4400 (303)
1/2	3/8	MBT8-TRB-FBT6-	35.8	22.2	19.1	15.0	11.9	5300 (365)	2600 (179)

Male NPT Threads

Female ISO Parallel Threads

P-NPT Size	Px-BG Size	Basic Ordering Number	Dimension, mm					Working Pressure psig (bar)
			L	F	B	Bx	E	316 SS, Steel
3/8	1/4	NPT6-TRB-FBP4-	30.2	19.1	14.2	12.9	5.6	5700 (392)
1/2	3/8	NPT8-TRB-FBP6-	35.8	22.2	19.1	14.2	6.6	5700 (392)
3/4	1/2	NPT12-TRB-FBP8-	41.4	27.0	19.1	18.8	7.1	3900 (268)

Male ISO Parallel Threads

Female NPT Threads

P-BG Size	Px-NPT Size	Basic Ordering Number	Dimension, mm					Working Pressure psig (bar)	
			L	F	B	Bx	E	316 SS, Steel	Brass
1/4	1/8	MBP4-TRB-FNPT2-	26.9	14.3	12.9	10.4	4.5	6500 (447)	3200 (220)
3/8	1/4	MBP6-TRB-FNPT4-	31.0	19.1	14.2	15	7.1	6600 (454)	3300 (227)
1/2	3/8	MBP8-TRB-FNPT6-	35.8	22.2	18.8	15	6.6	5300 (365)	2600 (179)

Male SAE Straight Threads

Female MS Straight Threads

P-SAE/MS Thread Size	Px-SAE/MS Thread Size	Basic Ordering Number	Dimension, mm					Working Pressure psig (bar)
			L	F	B	Bx	E	316 SS, Steel
9/16-18	7/16-20	OST9-TRB-FST7-	28.4	20.6	9.9	14.0	7.1	4500 (310)
3/4-16	7/16-20	OST12-TRB-FST7-	24.9	22.2	11.2	14.0	9.9	4500 (310)
3/4-16	9/16-18	OST12-TRB-FST9-	30.2	25.4	11.2	16.0	10.7	4500 (310)
7/8-14	9/16-18	OST14-TRB-FST9-	27.9	25.4	12.7	16.0	12.7	3600 (248)
7/8-14	3/4-16	OST14-TRB-FST12-	36.1	30.2	12.7	18.0	12.7	3600 (248)
1 1/16-12	3/4-16	OST17-TRB-FST12-	32.3	31.8	15.0	18.0	16.5	3600 (248)
1 5/16-12	1 1/16-12	OST21-TRB-FST17-	40.9	41.3	15.0	24.0	22.1	2900 (199)
1 5/8-12	1 5/16-12	OST26-TRB-FST21-	50.3	54.0	15.0	24.0	27.7	2300 (158)
1 7/8-12	1 5/16-12	OST30-TRB-FST21-	50.3	54.0	15.0	24.0	31.2	2300 (158)

Pipe Plugs

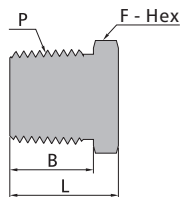

Male NPT Threads

P-NPT Size	Basic Ordering Number	Dimension, mm		
		L	F	B
1/16	TP-NPT1-	14.2	7.9	9.7
1/8	TP-NPT2-	14.2	11.1	9.7
1/4	TP-NPT4-	19.1	14.3	14.2
3/8	TP-NPT6-	19.8	17.5	14.2
1/2	TP-NPT8-	24.6	22.2	19.1
3/4	TP-NPT12-	30.7	27.0	19.1
1	TP-NPT16-	38.1	34.9	23.9
1 1/4	TP-NPT20-	38.4	44.5	23.9
1 1/2	TP-NPT24-	43.7	50.8	26.2
2	TP-NPT32-	50.8	69.9	26.2

Male ISO Tapered Threads

P-BSPT Size	Basic Ordering Number	Dimension, mm		
		L	F	B
1/16	TP-MBT1-	14.2	7.9	9.7
1/8	TP-MBT2-	14.2	11.1	9.7
1/4	TP-MBT4-	19.1	14.3	14.2
3/8	TP-MBT6-	19.8	17.5	14.2
1/2	TP-MBT8-	24.6	22.2	19.1
3/4	TP-MBT12-	30.7	27.0	19.1
1	TP-MBT16-	38.1	34.9	23.9
1 1/4	TP-MBT20-	38.4	44.5	23.9
1 1/2	TP-MBT24-	43.7	50.8	26.2
2	TP-MBT32-	50.8	69.9	26.2

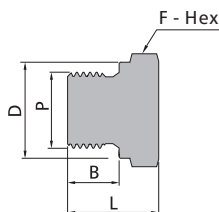

Male ISO parallel Threads

P-BS Size	Basic Ordering Number	Dimension, mm			
		L	F	B	D
1/8	TP-MBS2-	14.0	14.3	7.1	13.7
1/4	TP-MBS4-	19.8	19.1	11.2	18.0
3/8	TP-MBS6-	19.8	22.2	11.2	21.8
1/2	TP-MBS8-	25.1	27.0	14.0	25.9
3/4	TP-MBS12-	28.7	33.3	15.7	32.0
1	TP-MBS16-	30.7	41.3	18.0	39.1

Male Metric Threads

P-Metric Size	Basic Ordering Number	Dimension, mm			
		L	F	B	D
M14 x 1.5	TP-BSMS14-	21	20.6	12	18.8
M16 x 1.5	TP-BSMS16-	23	22.2	12	20.8
M18 x 1.5	TP-BSMS18-	25	23.8	12	22.8
M20 x 1.5	TP-BSMS20-	26.5	25.4	14	24.8
M22 x 1.5	TP-BSMS22-	28.5	28.6	14	26.8
M24 x 1.5	TP-BSMS24-	29	35.0	14	28.8
M27 x 2	TP-BSMS27-	30	36.5	16	31.8

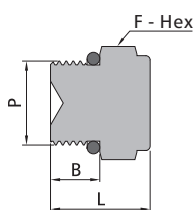

Male SAE/MS Straight Threads

P-SAE/MS Thread Size	Basic Ordering Number	Dimension, mm		
		L	F	B
7/16-20	TP-OST7-	19.3	14.3	9.1
9/16-18	TP-OST9-	20.8	17.5	9.9
3/4-16	TP-OST12-	22.6	22.2	11.2
1 1/16-12	TP-OST17-	28.4	31.8	15.0
1 5/16-12	TP-OST21-	30.0	38.1	15.0

Pipe Plugs

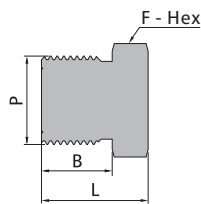

Male Metric Threads

P-Metric Size	Basic Ordering Number	Dimension, mm		
		L	F	B
M14 x 1.5	TP-MS14-	18	16	13
M16 x 1.5	TP-MS16-	20	18	14
M18 x 1.5	TP-MS18-	22	19	15
M20 x 1.5	TP-MS20-	24	22	16
M22 x 1.5	TP-MS22-	26	24	17
M24 x 1.5	TP-MS24-	26	27	17
M27 x 2	TP-MS27-	27	30	18
M30 x 2	TP-MS30-	32	32	20

Hollow Hex Plugs

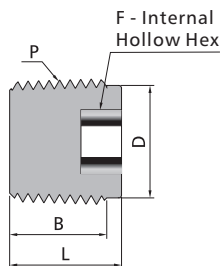

Male ISO Tapered Threads

P-BSPT Size	Basic Ordering Number	Dimension, mm			
		L	F	B	D
1/16	THP-MBT1-	7.6	4.0	7.4	7.4
1/8	THP-MBT2-	10.4	4.8	7.4	9.4
1/4	THP-MBT4-	15.5	6.4	12.4	12.1
3/8	THP-MBT6-	15.5	7.9	12.4	15.7
1/2	THP-MBT8-	19.3	9.5	16.2	19.3
3/4	THP-MBT12-	19.8	14.3	16.7	25.7
1	THP-MBT16-	20.8	15.9	17.7	31.8

Hollow Hex Plugs

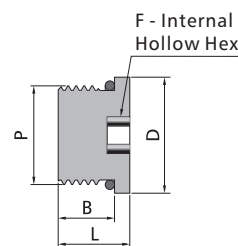
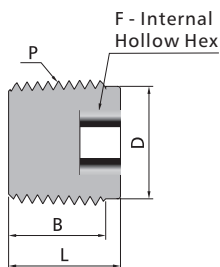

Male NPT Threads

P-NPT Size	Basic Ordering Number	Dimension, mm			
		L	F	B	D
1/16	THP-NPT1-	7.6	4.0	7.4	7.4
1/8	THP-NPT2-	10.4	4.8	7.4	9.4
1/4	THP-NPT4-	15.5	6.4	12.4	12.1
3/8	THP-NPT6-	15.0	7.9	11.9	15.7
1/2	THP-NPT8-	19.3	9.5	16.2	19.3
3/4	THP-NPT12-	19.8	14.3	16.7	25.7
1	THP-NPT16-	20.8	15.9	17.7	31.8

Male SAE/MS Straight Threads

P-SAE/MS Thread Size	Basic Ordering Number	Dimension, mm			
		L	F	B	D
7/16-20	THP-OST7-	11.4	4.8	9.1	14.2
9/16-18	THP-OST9-	12.2	6.4	9.9	17.5
3/4-16	THP-OST12-	14.2	7.9	11.2	22.4
1 1/16-12	THP-OST17-	19.1	14.3	15.0	31.8
1 5/16-12	THP-OST21-	19.1	15.9	15.0	38.1

Pipe Caps

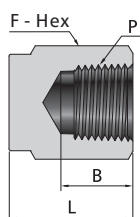

Female NPT Threads

P-NPT Size	Basic Ordering Number	Dimension, mm			Working Pressure psig (bar)	
		L	F	B	316 SS, Steel	Brass
1/16	PC-FNPT1-	12.7	11.1	9.9	6700 (460)	3300 (227)
1/8	PC-FNPT2-	19.1	14.3	10.4	6500 (447)	3200 (220)
1/4	PC-FNPT4-	23.1	19.1	15.0	6600 (454)	3300 (277)
3/8	PC-FNPT6-	26.2	22.2	15.0	5300 (365)	2600 (179)
1/2	PC-FNPT8-	34.0	27.0	19.8	4900 (337)	2400 (165)
3/4	PC-FNPT12-	36.6	33.3	20.6	4600 (316)	2300 (158)
1	PC-FNPT16-	41.1	41.3	25.4	4400 (303)	2200 (151)
Heavy-Wall Female NPT Threads						
1/4	PC1-FNPT4	28.2	25.4	15.0	10000 (689)	/
1/2	PC1-FNPT8	40.1	38.1	19.8	10000 (689)	/

Female ISO Tapered Threads

P-BSPT Size	Basic Ordering Number	Dimension, mm			Working Pressure psig (bar)	
		L	F	B	316 SS, Steel	Brass
1/16	PC-FBT1-	12.7	11.1	9.9	6700 (460)	3300 (227)
1/8	PC-FBT2-	19.1	14.3	10.4	6500 (447)	3200 (220)
1/4	PC-FBT4-	23.1	19.1	15.0	6600 (454)	3300 (277)
3/8	PC-FBT6-	26.2	22.2	15.0	5300 (365)	2600 (179)
1/2	PC-FBT8-	34.0	27.0	19.8	4900 (337)	2400 (165)
3/4	PC-FBT12-	36.6	33.3	20.6	4600 (316)	2300 (158)
1	PC-FBT16-	41.1	41.3	25.4	4400 (303)	2200 (151)

Adapters

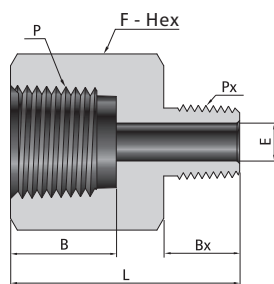

Female NPT Threads

Male NPT Threads

P-NPT Size	Px-NPT Size	Basic Ordering Number	Dimension, mm					Working Pressure psig (bar)	
			L	F	B	Bx	E	316 SS, Steel	Brass
1/8	1/16	FNPT2-TA-NPT1-	27.7	14.3	10.4	9.7	3.0	6500 (447)	3200 (220)
1/8	1/8	FNPT2-TA-NPT2-	27.9	14.3	10.4	9.7	4.8	6500 (447)	3200 (220)
1/4	1/16	FNPT4-TA-NPT1-	30.5	19.1	15.0	9.7	3.0	6600 (454)	3300 (227)
1/4	1/8	FNPT4-TA-NPT2-	32.0	19.1	15.0	9.7	4.8	6600 (454)	3300 (227)
1/4	1/4	FNPT4-TA-NPT4-	35.6	19.1	15.0	14.2	7.1	6600 (454)	3300 (227)
3/8	1/16	FNPT6-TA-NPT1-	31.8	22.2	15.0	9.7	3.0	5300 (365)	2600 (179)
3/8	1/8	FNPT6-TA-NPT2-	33.8	22.2	15.0	9.7	4.8	5300 (365)	2600 (179)
3/8	1/4	FNPT6-TA-NPT4-	38.1	22.2	15.0	14.2	7.1	5300 (365)	2600 (179)
3/8	3/8	FNPT6-TA-NPT6-	38.4	22.2	15.0	14.2	9.7	5300 (365)	2600 (179)
1/2	1/8	FNPT8-TA-NPT2-	40.1	27.0	19.8	9.7	4.8	4900 (337)	2400 (165)
1/2	1/4	FNPT8-TA-NPT4-	44.7	27.0	19.8	14.2	7.1	4900 (337)	2400 (165)
1/2	3/8	FNPT8-TA-NPT6-	44.4	27.0	19.8	14.2	9.6	4900 (337)	2400 (165)
1/2	1/2	FNPT8-TA-NPT8-	49.3	27.0	19.8	19.1	11.9	4900 (337)	2400 (165)
3/4	1/8	FNPT12-TA-NPT2-	39.6	33.3	20.6	9.7	4.8	4600 (316)	2300 (158)
3/4	1/4	FNPT12-TA-NPT4-	47.0	33.3	20.6	14.2	7.1	4600 (316)	2300 (158)
3/4	3/8	FNPT12-TA-NPT6-	46.2	33.3	20.6	14.2	9.7	4600 (316)	2300 (158)
3/4	1/2	FNPT12-TA-NPT8-	51.3	33.3	20.6	19.1	11.9	4600 (316)	2300 (158)
3/4	3/4	FNPT12-TA-NPT12-	51.3	33.3	20.6	19.1	15.7	4600 (316)	2300 (158)
1	1/8	FNPT16-TA-NPT2-	46.0	41.3	25.4	9.7	4.8	4400 (303)	2200 (151)
1	1/4	FNPT16-TA-NPT4-	49.8	41.3	25.4	14.2	7.1	4400 (303)	2200 (151)
1	3/8	FNPT16-TA-NPT6-	50.8	41.3	25.4	14.2	9.7	4400 (303)	2200 (151)
1	1/2	FNPT16-TA-NPT8-	54.9	41.3	25.4	19.1	11.9	4400 (303)	2200 (151)
1	3/4	FNPT16-TA-NPT12-	55.1	41.3	25.4	19.1	15.7	4400 (303)	2200 (151)
1	1	FNPT16-TA-NPT16-	57.9	41.3	25.4	23.9	22.4	4400 (303)	2200 (151)
1 1/4	1	FNPT20-TA-NPT16-	62.7	54.0	25.4	23.9	22.4	5000 (344)	2500 (172)
Heavy-Wall Female to male NPT Threads									
1/4	1/4	FNPT4-TA1-NPT4-	36.3	25.4	15.0	14.2	5.8	10000 (689)	/
1/2	1/4	FNPT8-TA1-NPT4-	46.0	38.1	19.8	14.2	5.8	10000 (689)	/
1/2	1/2	FNPT8-TA1-NPT8-	51.3	38.1	19.8	19.1	9.9	10000 (689)	/

Adapters

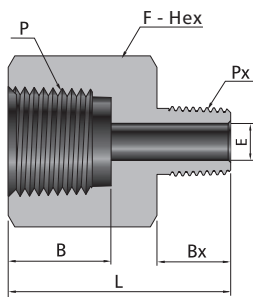

Female NPT Threads

P-NPT Size	Px-BSPT Size	Basic Ordering Number	Dimension, mm					Working Pressure psig (bar)	
			L	F	B	Bx	E	316 SS, Steel	Brass
1/8	1/8	FNPT2-TA-MBT2-	27.7	14.3	10.4	9.7	4.8	6500 (447)	3200 (220)
1/4	1/4	FNPT4-TA-MBT4-	36.1	19.1	15.0	14.2	7.1	6600 (454)	3300 (227)
3/8	3/8	FNPT6-TA-MBT6-	38.1	22.2	15.0	14.2	9.7	5300 (365)	2600 (179)
1/2	1/2	FNPT8-TA-MBT8-	49.3	27.0	19.8	19.1	11.9	4900 (337)	2400 (165)
3/4	3/4	FNPT12-TA-MBT12-	51.3	33.3	20.6	19.1	15.7	4600 (316)	2300 (158)
1	1	FNPT16-TA-MBT16-	58.4	41.3	25.4	23.9	22.4	4400 (303)	2200 (151)

Male ISO Tapered Threads

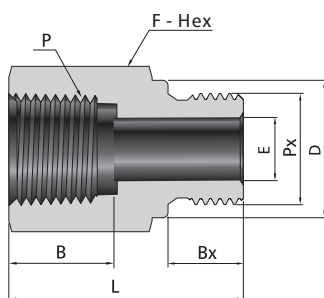

Female NPT Threads

P-NPT Size	Px-BS Size	Basic Ordering Number	Dimension, mm						Working Pressure psig (bar)	
			L	F	B	Bx	D	E	316 SS, Steel	Brass
1/8	1/8	FNPT2-TA-MBS2-	25.1	14.3	9.9	7.1	13.7	4.1	6500 (447)	3200 (220)
1/4	1/4	FNPT4-TA-MBS4-	33.5	19.1	10.4	11.2	18.0	5.8	6600 (454)	3300 (227)
3/8	3/8	FNPT6-TA-MBS6-	35.8	22.2	15.0	11.2	21.6	7.9	5300 (365)	2600 (179)
1/2	1/2	FNPT8-TA-MBS8-	44.2	27.0	15.0	14.2	25.9	11.9	4900 (337)	2400 (165)
3/4	3/4	FNPT12-TA-MBS12-	48.0	33.3	20.6	15.7	32.0	15.7	4600 (316)	2300 (158)
1	1	FNPT16-TA-MBS16-	53.3	41.3	25.4	18.3	38.9	19.8	4400 (303)	2200 (151)

Male ISO Parallel Threads

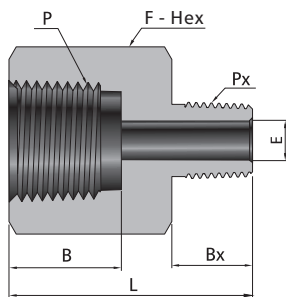

Female ISO Tapered Threads

P-BSPT Size	Px-BSPT Size	Basic Ordering Number	Dimension, mm					Working Pressure psig (bar)	
			L	F	B	Bx	E	316 SS, Steel	Brass
1/8	1/8	FBT2-TA-MBT2-	27.7	14.3	10.4	9.7	4.8	6500 (447)	3200 (220)
1/4	1/8	FBT4-TA-MBT2-	32.0	19.1	15.0	9.7	4.8	6600 (454)	3300 (227)
1/4	1/4	FBT4-TA-MBT4-	36.1	19.1	15.0	14.2	7.1	6600 (454)	3300 (227)
3/8	1/4	FBT6-TA-MBT4-	38.1	22.2	15.0	14.2	7.1	5300 (365)	2600 (179)
3/8	3/8	FBT6-TA-MBT6-	38.1	22.2	15.0	14.2	9.7	5300 (365)	2600 (179)
1/2	1/4	FBT8-TA-MBT4-	44.7	27.0	19.8	14.2	7.1	4900 (337)	2400 (165)
1/2	3/8	FBT8-TA-MBT6-	44.4	27.0	19.8	14.2	9.7	4900 (337)	2400 (165)
1/2	1/2	FBT8-TA-MBT8-	49.5	27.0	19.8	19.1	11.9	4900 (337)	2400 (165)
3/4	3/4	FBT12-TA-MBT12-	51.3	33.3	20.6	19.1	15.7	4600 (316)	2300 (158)
1	1	FBT16-TA-MBT16-	58.4	41.3	25.4	23.9	22.4	4400 (303)	2200 (151)

Male ISO Tapered Threads

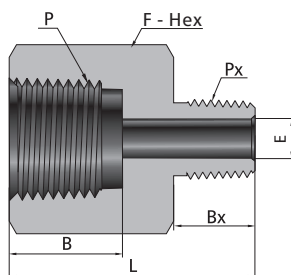

Female ISO Tapered Threads

P-BSPT Size	Px-NPT Size	Basic Ordering Number	Dimension, mm					Working Pressure psig (bar)	
			L	F	B	Bx	E	316 SS, Steel	Brass
1/8	1/8	FBT2-TA-NPT2-	27.7	14.3	10.4	9.7	4.8	6500 (447)	3200 (220)
1/4	1/4	FBT4-TA-NPT4-	36.3	19.1	15.0	14.2	7.1	6600 (454)	3300 (227)
3/8	3/8	FBT6-TA-NPT6-	38.4	22.2	15.0	14.2	9.6	5300 (365)	2600 (179)
1/2	1/2	FBT8-TA-NPT8-	49.8	27.0	19.8	19.1	11.9	4900 (337)	2400 (165)
3/4	3/4	FBT12-TA-NPT12-	51.3	33.3	20.6	19.1	15.7	4600 (316)	2300 (158)
1	1	FBT16-TA-NPT16-	58.4	41.3	25.4	23.9	22.4	4400 (303)	2200 (151)

Male NPT Threads

Adapters

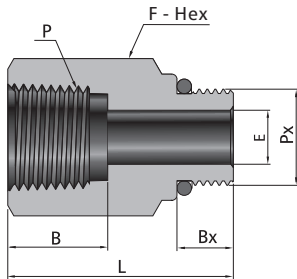

Female NPT Threads

P-NPT Size	Px-SAE/MS Thread Size	Basic Ordering Number	Dimension, mm					Working Pressure psig (bar) 316 SS, Steel
			L	F	B	Bx	E	
1/4	7/16-20	FNPT4-TA-OST7-	33.5	19.1	15.0	9.1	5.1	4500 (310)
3/8	9/16-18	FNPT6-TA-OST9-	35.3	23.8	15.0	9.9	7.1	4500 (310)
1/2	3/4-16	FNPT8-TA-OST12-	44.7	27.0	19.8	11.2	10.7	4500 (310)
3/4	1 1/16-12	FNPT12-TA-OST17-	50.5	34.9	20.6	15.0	16.7	3600 (248)
1	1 5/16-12	FNPT16-TA-OST21-	53.8	41.3	25.4	15.0	22.4	2900 (199)

Male SAE/MS Straight Threads

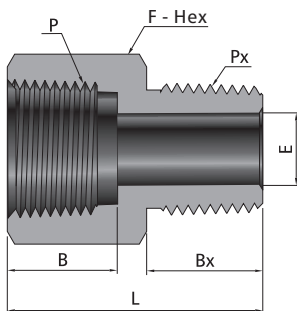

Female ISO Parallel Threads

P-BG Size	Px-NPT Size	Basic Ordering Number	Dimension, mm					Working Pressure psig (bar) 316 SS, Steel
			L	F	B	Bx	E	
1/8	1/8	FBP2-TA-NPT2-	21.8	14.3	6.5	9.7	4.8	6100 (420)
1/4	1/4	FBP4-TA-NPT4-	30.2	19.1	12.9	14.2	5.6	5700 (392)
3/8	3/8	FBP6-TA-NPT6-	32.2	23.8	14.2	14.2	6.6	5700 (392)
1/2	1/2	FBP8-TA-NPT8-	42.7	27.0	18.8	19.1	7.1	3900 (268)

Male NPT Threads

Male Elbows

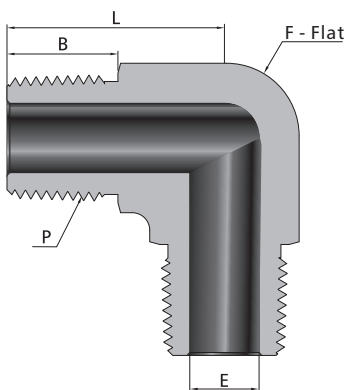

Male NPT Threads

P-NPT Size	Basic Ordering Number	Dimension, mm				Working Pressure psig (bar)	
		L	F	B	E	316 SS, Steel	Brass
1/16	NPT1-TME-NPT1-	18.3	9.5	9.7	3.0	11000 (757)	5500 (378)
1/8	NPT2-TME-NPT2-	22.4	11.1	9.7	4.8	10000 (689)	5000 (344)
1/4	NPT4-TME-NPT4-	26.7	12.7	14.2	7.1	8000 (551)	4000 (275)
3/8	NPT6-TME-NPT6-	29.7	17.5	14.2	9.6	7800 (537)	3900 (268)
1/2	NPT8-TME-NPT8-	36.8	20.6	19.1	11.9	7700 (530)	3800 (261)
3/4	NPT12-TME-NPT12-	40.4	27.0	19.1	15.7	7300 (502)	3600 (248)
1	NPT16-TME-NPT16-	50.0	34.9	23.9	22.4	5300 (365)	2600 (179)

Male ISO Tapered Pipe Threads

P-BSPT Size	Basic Ordering Number	Dimension, mm				Working Pressure psig (bar)	
		L	F	B	E	316 SS, Steel	Brass
1/16	MBT1-TME-MBT1-	18.3	9.5	9.7	3.0	11000 (757)	5500 (378)
1/8	MBT2-TME-MBT2-	22.4	11.1	9.7	4.8	10000 (689)	5000 (344)
1/4	MBT4-TME-MBT4-	26.7	12.7	14.2	7.1	8000 (551)	4000 (275)
3/8	MBT6-TME-MBT6-	29.7	17.5	14.2	9.7	7800 (537)	3900 (268)
1/2	MBT8-TME-MBT8-	36.8	20.6	19.1	11.9	7700 (530)	3800 (261)
3/4	MBT12-TME-MBT12-	40.4	27.0	19.1	15.7	7300 (502)	3600 (248)
1	MBT16-TME-MBT16-	50.0	34.9	23.9	22.4	5300 (365)	2600 (179)

Street Elbows

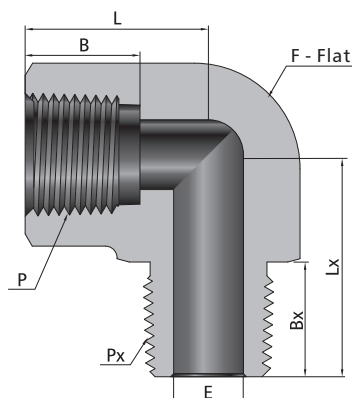

Female NPT Threads

Male NPT Threads

P-NPT Size	Px-NPT Size	Basic Ordering Number	Dimension, mm						Working Pressure psig (bar)	
			L	F	B	E	Lx	Bx	316 SS, Steel	Brass
1/16	1/16	FNPT1-TSE-NPT1-	21.8	11.1	9.9	3.0	22.4	9.7	9200 (633)	4600 (316)
1/16	1/8	FNPT1-TSE-NPT2-	21.8	11.1	9.9	4.8	22.4	9.7	9200 (633)	4600 (316)
1/16	1/4	FNPT1-TSE-NPT4-	22.4	14.3	9.9	4.8	27.7	14.2	8000 (551)	4000 (275)
1/16	3/8	FNPT1-TSE-NPT6-	22.4	17.5	9.9	4.8	29.7	14.2	7800 (537)	3900 (268)
1/8	1/16	FNPT2-TSE-NPT1-	26.4	12.7	10.4	3.0	22.1	9.7	6200 (426)	3100 (213)
1/8	1/8	FNPT2-TSE-NPT2-	26.4	12.7	10.4	4.8	22.1	9.7	6200 (426)	3100 (213)
1/8	1/4	FNPT2-TSE-NPT4-	22.4	14.3	10.4	7.1	27.7	14.2	6500 (447)	3200 (220)
1/8	3/8	FNPT2-TSE-NPT6-	22.4	17.5	10.4	7.1	29.7	14.2	7800 (537)	3900 (268)
1/8	1/2	FNPT2-TSE-NPT8-	24.1	20.6	10.4	7.1	36.8	19.1	7700 (530)	3800 (261)
1/8	3/4	FNPT2-TSE-NPT12-	25.4	27.0	10.4	7.1	40.4	19.1	7300 (502)	3600 (248)
1/8	1	FNPT2-TSE-NPT16-	26.4	34.9	10.4	7.1	50.0	23.9	5300 (365)	2600 (179)
1/4	1/8	FNPT4-TSE-NPT2-	29.7	17.5	15.0	4.8	25.4	9.7	7200 (496)	3600 (248)
1/4	1/4	FNPT4-TSE-NPT4-	29.7	17.5	15.0	7.1	29.7	14.2	7200 (496)	3600 (248)
1/4	3/8	FNPT4-TSE-NPT6-	29.7	17.5	15.0	8.6	29.7	14.2	7200 (496)	3600 (248)
1/4	1/2	FNPT4-TSE-NPT8-	25.4	20.6	15.0	8.6	36.8	19.1	7200 (496)	3600 (248)
1/4	3/4	FNPT4-TSE-NPT12-	25.4	27.0	15.0	8.6	40.4	19.1	7300 (502)	3600 (248)
1/4	1	FNPT4-TSE-NPT16-	41.4	34.9	15.0	8.6	50.0	23.9	5300 (365)	2600 (179)
3/8	1/4	FNPT6-TSE-NPT4-	36.1	20.6	15.0	7.1	32.0	14.2	5600 (385)	2800 (192)
3/8	3/8	FNPT6-TSE-NPT6-	36.1	20.6	15.0	9.6	32.0	14.2	5600 (385)	2800 (192)
3/8	1/2	FNPT6-TSE-NPT8-	36.1	20.6	15.0	11.9	36.8	19.1	5600 (385)	2800 (192)
3/8	3/4	FNPT6-TSE-NPT12-	31.2	27.0	15.0	11.9	40.4	19.1	7300 (502)	3600 (248)
3/8	1	FNPT6-TSE-NPT16-	41.4	34.9	15.0	11.9	50.0	23.9	5300 (365)	2600 (179)
1/2	1/4	FNPT8-TSE-NPT4-	39.6	25.4	19.8	7.1	35.1	14.2	5600 (385)	2800 (192)
1/2	3/8	FNPT8-TSE-NPT6-	39.6	25.4	19.8	9.6	35.1	14.2	5600 (385)	2800 (192)
1/2	1/2	FNPT8-TSE-NPT8-	39.6	25.4	19.8	11.9	39.6	19.1	5600 (385)	2800 (192)
1/2	3/4	FNPT8-TSE-NPT12-	31.2	27.0	19.8	15.7	40.4	19.1	5600 (385)	2800 (192)
1/2	1	FNPT8-TSE-NPT16-	41.4	34.9	19.8	15.7	50.0	23.9	5300 (365)	2600 (179)
3/4	3/4	FNPT12-TSE-NPT12-	48.8	31.8	20.6	15.7	42.4	19.1	5100 (351)	2500 (172)
3/4	1	FNPT12-TSE-NPT16-	41.4	34.9	20.6	22.4	50.0	23.9	5100 (351)	2500 (172)
1	1	FNPT16-TSE-NPT16-	48.5	42.9	25.4	22.4	49.3	23.9	5300 (365)	2600 (179)
1 1/4	1 1/4	FNPT20-TSE-NPT20-	60.5	50.8	25.4	31.8	60.5	23.9	3100 (213)	1600 (110)

Street Elbows

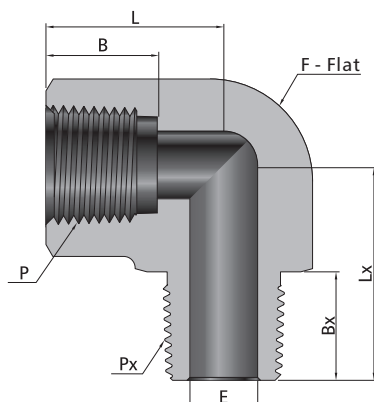

Female ISO Tapered Pipe Threads

Male ISO Tapered Threads

P-BSPT Size	Px-BSPT Size	Basic Ordering Number	Dimension, mm						Working Pressure psig (bar)	
			L	F	B	E	Lx	Bx	316 SS, Steel	Brass
1/16	1/16	FBT1-TSE-MBT1-	21.8	11.1	9.9	3.0	22.4	9.7	9200 (633)	4600 (316)
1/16	1/8	FBT1-TSE-MBT2-	21.8	11.1	9.9	4.8	22.4	9.7	9200 (633)	4600 (316)
1/16	1/4	FBT1-TSE-MBT4-	22.4	14.3	9.9	4.8	27.7	14.2	8000 (551)	4000 (275)
1/16	3/8	FBT1-TSE-MBT6-	22.4	17.5	9.9	4.8	29.7	14.2	7800 (537)	3900 (268)
1/8	1/16	FBT2-TSE-MBT1-	26.4	12.7	10.4	3.0	22.1	9.7	6200 (426)	3100 (213)
1/8	1/8	FBT2-TSE-MBT2-	26.4	12.7	10.4	4.8	22.1	9.7	6200 (426)	3100 (213)
1/8	1/4	FBT2-TSE-MBT4-	22.4	14.3	10.4	7.1	27.7	14.2	6500 (447)	3200 (220)
1/8	3/8	FBT2-TSE-MBT6-	22.4	17.5	10.4	7.1	29.7	14.2	7800 (537)	3900 (268)
1/8	1/2	FBT2-TSE-MBT8-	24.1	20.6	10.4	7.1	36.8	19.1	7700 (530)	3800 (261)
1/8	3/4	FBT2-TSE-MBT12-	25.4	27.0	10.4	7.1	40.4	19.1	7300 (502)	3600 (248)
1/8	1	FBT2-TSE-MBT16-	26.4	34.9	10.4	7.1	50.0	23.9	5300 (365)	2600 (179)
1/4	1/8	FBT4-TSE-MBT2-	29.7	17.5	15.0	4.8	25.4	9.7	7200 (496)	3600 (248)
1/4	1/4	FBT4-TSE-MBT4-	29.7	17.5	15.0	7.1	29.7	14.2	7200 (496)	3600 (248)
1/4	3/8	FBT4-TSE-MBT6-	29.7	17.5	15.0	8.6	29.7	14.2	7200 (496)	3600 (248)
1/4	1/2	FBT4-TSE-MBT8-	25.4	20.6	15.0	8.6	36.8	19.1	7200 (496)	3600 (248)
1/4	3/4	FBT4-TSE-MBT12-	25.4	27.0	15.0	8.6	40.4	19.1	7300 (502)	3600 (248)
1/4	1	FBT4-TSE-MBT16-	41.4	34.9	15.0	8.6	50.0	23.9	5300 (365)	2600 (179)
3/8	1/4	FBT6-TSE-MBT4-	36.1	20.6	15.0	7.1	32.0	14.2	5600 (385)	2800 (192)
3/8	3/8	FBT6-TSE-MBT6-	36.1	20.6	15.0	9.7	32.0	14.2	5600 (385)	2800 (192)
3/8	1/2	FBT6-TSE-MBT8-	36.1	20.6	15.0	11.9	36.8	19.1	5600 (385)	2800 (192)
3/8	3/4	FBT6-TSE-MBT12-	31.2	27.0	15.0	11.9	40.4	19.1	7300 (502)	3600 (248)
3/8	1	FBT6-TSE-MBT16-	41.4	34.9	15.0	11.9	50.0	23.9	5300 (365)	2600 (179)
1/2	1/4	FBT8-TSE-MBT4-	39.6	25.4	19.8	7.1	35.1	14.2	5600 (385)	2800 (192)
1/2	3/8	FBT8-TSE-MBT6-	39.6	25.4	19.8	9.7	35.1	14.2	5600 (385)	2800 (192)
1/2	1/2	FBT8-TSE-MBT8-	39.6	25.4	19.8	11.9	39.6	19.1	5600 (385)	2800 (192)
1/2	3/4	FBT8-TSE-MBT12-	31.2	27.0	19.8	15.7	40.4	19.1	5600 (385)	2800 (192)
1/2	1	FBT8-TSE-MBT16-	41.4	34.9	19.8	15.7	50.0	23.9	5300 (365)	2600 (179)
3/4	3/4	FBT12-TSE-MBT12-	48.8	31.8	20.6	15.7	42.4	19.1	5100 (351)	2500 (172)
3/4	1	FBT12-TSE-MBT16-	41.4	34.9	20.6	22.4	50.0	23.9	5100 (351)	2500 (172)
1	1	FBT16-TSE-MBT16-	48.5	42.9	25.4	22.4	49.3	23.9	5300 (365)	2600 (179)
1 1/4	1 1/4	FBT20-TSE-MBT20-	60.5	50.8	25.4	31.8	60.5	23.9	3100 (213)	1600 (110)

45° Street Elbows

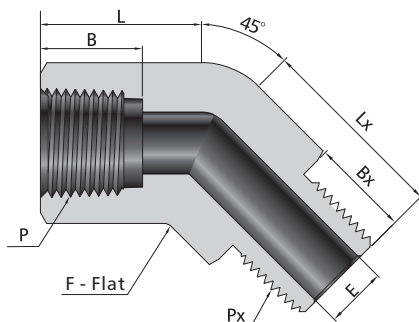

Female NPT Threads

Male NPT Threads

P-NPT Size	Px-NPT Size	Basic Ordering Number	Dimension, mm						Working Pressure psig (bar)	
			L	F	B	E	Lx	Bx	316 SS, Steel	Brass
1/16	1/16	FNPT1-T45E-NPT1-	16.8	11.1	9.9	3.0	16.8	9.7	9200 (633)	4600 (316)
1/16	1/8	FNPT1-T45E-NPT2-	16.8	11.1	9.9	4.8	16.8	9.7	9200 (633)	4600 (316)
1/16	1/4	FNPT1-T45E-NPT4-	16.8	14.3	9.9	4.8	21.8	14.2	8000 (551)	4000 (275)
1/16	3/8	FNPT1-T45E-NPT6-	22.4	17.5	9.9	4.8	23.8	14.2	7800 (537)	3900 (268)
1/8	1/16	FNPT2-T45E-NPT1-	20.2	12.7	10.4	3.0	17.2	9.7	6200 (426)	3100 (213)
1/8	1/8	FNPT2-T45E-NPT2-	20.2	12.7	10.4	4.8	17.2	9.7	6200 (426)	3100 (213)
1/8	1/4	FNPT2-T45E-NPT4-	16.8	14.3	10.4	7.1	21.8	14.2	6500 (447)	3200 (220)
1/8	3/8	FNPT2-T45E-NPT6-	22.4	17.5	10.4	7.1	23.8	14.2	7800 (537)	3900 (268)
1/8	1/2	FNPT2-T45E-NPT8-	22.2	20.6	10.4	7.1	29.0	19.1	7700 (530)	3800 (261)
1/8	3/4	FNPT2-T45E-NPT12-	25.4	27.0	10.4	7.1	30.5	19.1	7300 (502)	3600 (248)
1/8	1	FNPT2-T45E-NPT16-	26.4	34.9	10.4	7.1	49.3	23.9	5300 (365)	2600 (179)
1/4	1/8	FNPT4-T45E-NPT2-	25.4	17.5	15.0	4.8	19.3	9.7	7200 (496)	3600 (248)
1/4	1/4	FNPT4-T45E-NPT4-	25.4	17.5	15.0	7.1	19.3	14.2	7200 (496)	3600 (248)
1/4	3/8	FNPT4-T45E-NPT6-	25.4	17.5	15.0	8.6	23.8	14.2	7200 (496)	3600 (248)
1/4	1/2	FNPT4-T45E-NPT8-	22.2	20.6	15.0	8.6	29.0	19.1	7200 (496)	3600 (248)
1/4	3/4	FNPT4-T45E-NPT12-	25.4	27.0	15.0	8.6	30.5	19.1	7300 (502)	3600 (248)
1/4	1	FNPT4-T45E-NPT16-	32.0	34.9	15.0	8.6	37.6	23.9	5300 (365)	2600 (179)
3/8	1/4	FNPT6-T45E-NPT4-	27.0	20.6	15.0	7.1	24.2	14.2	5600 (385)	2800 (192)
3/8	3/8	FNPT6-T45E-NPT6-	27.0	20.6	15.0	9.7	24.2	14.2	5600 (385)	2800 (192)
3/8	1/2	FNPT6-T45E-NPT8-	27.0	20.6	15.0	11.9	29.0	19.1	5600 (385)	2800 (192)
3/8	3/4	FNPT6-T45E-NPT12-	27.0	27.0	15.0	11.9	30.5	19.1	7300 (502)	3600 (248)
3/8	1	FNPT6-T45E-NPT16-	32.0	34.9	15.0	11.9	37.6	23.9	5300 (365)	2600 (179)
1/2	1/4	FNPT8-T45E-NPT4-	32.0	25.4	19.8	7.1	25.2	14.2	5600 (385)	2800 (192)
1/2	3/8	FNPT8-T45E-NPT6-	32.0	25.4	19.8	9.7	25.2	14.2	5600 (385)	2800 (192)
1/2	1/2	FNPT8-T45E-NPT8-	32.0	25.4	19.8	11.9	32.0	19.1	5600 (385)	2800 (192)
1/2	3/4	FNPT8-T45E-NPT12-	32.5	27.0	19.8	15.7	30.5	19.1	5600 (385)	2800 (192)
1/2	1	FNPT8-T45E-NPT16-	37.6	34.9	19.8	15.7	37.6	23.9	5300 (365)	2600 (179)
3/4	3/4	FNPT12-T45E-NPT12-	34.5	31.8	20.6	15.7	34.5	19.1	5100 (351)	2500 (172)
3/4	1	FNPT12-T45E-NPT16-	37.6	34.9	20.6	22.4	37.6	23.9	5100 (351)	2500 (172)
1	1	FNPT16-T45E-NPT16-	46.0	42.9	25.4	22.4	46.0	23.9	5300 (365)	2600 (179)
1 1/4	1 1/4	FNPT20-T45E-NPT20-	50.8	50.8	25.4	31.8	50.8	23.9	3100 (213)	1600 (110)

45° Street Elbows

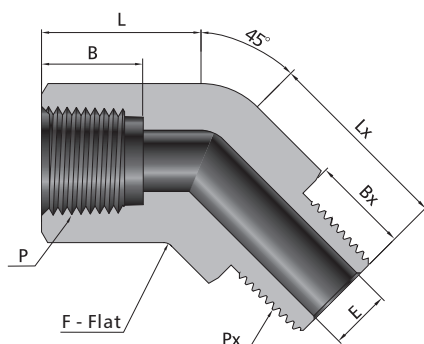

Female ISO Tapered Threads

Male ISO Tapered Threads

P-BSPT Size	Px-BSPT Size	Basic Ordering Number	Dimension, mm						Working Pressure psig (bar)	
			L	F	B	E	Lx	Bx	316 SS, Steel	Brass
1/16	1/16	FBT1-T45E-MBT1-	16.8	11.1	9.9	3.0	16.8	9.7	9200 (633)	4600 (316)
1/16	1/8	FBT1-T45E-MBT2-	16.8	11.1	9.9	4.8	16.8	9.7	9200 (633)	4600 (316)
1/16	1/4	FBT1-T45E-MBT4-	16.8	14.3	9.9	4.8	21.8	14.2	8000 (551)	4000 (275)
1/16	3/8	FBT1-T45E-MBT6-	22.4	17.5	9.9	4.8	23.8	14.2	7800 (537)	3900 (268)
1/8	1/16	FBT2-T45E-MBT1-	20.2	12.7	10.4	3.0	17.2	9.7	6200 (426)	3100 (213)
1/8	1/8	FBT2-T45E-MBT2-	20.2	12.7	10.4	4.8	17.2	9.7	6200 (426)	3100 (213)
1/8	1/4	FBT2-T45E-MBT4-	16.8	14.3	10.4	7.1	21.8	14.2	6500 (447)	3200 (220)
1/8	3/8	FBT2-T45E-MBT6-	22.4	17.5	10.4	7.1	23.8	14.2	7800 (537)	3900 (268)
1/8	1/2	FBT2-T45E-MBT8-	22.2	20.6	10.4	7.1	29.0	19.1	7700 (530)	3800 (261)
1/8	3/4	FBT2-T45E-MBT12-	25.4	27.0	10.4	7.1	30.5	19.1	7300 (502)	3600 (248)
1/8	1	FBT2-T45E-MBT16-	26.4	34.9	10.4	7.1	49.3	23.9	5300 (365)	2600 (179)
1/4	1/8	FBT4-T45E-MBT2-	25.4	17.5	15.0	4.8	19.3	9.7	7200 (496)	3600 (248)
1/4	1/4	FBT4-T45E-MBT4-	25.4	17.5	15.0	7.1	19.3	14.2	7200 (496)	3600 (248)
1/4	3/8	FBT4-T45E-MBT6-	25.4	17.5	15.0	8.6	23.8	14.2	7200 (496)	3600 (248)
1/4	1/2	FBT4-T45E-MBT8-	22.2	20.6	15.0	8.6	29.0	19.1	7200 (496)	3600 (248)
1/4	3/4	FBT4-T45E-MBT12-	25.4	27.0	15.0	8.6	30.5	19.1	7300 (502)	3600 (248)
1/4	1	FBT4-T45E-MBT16-	32.0	34.9	15.0	8.6	37.6	23.9	5300 (365)	2600 (179)
3/8	1/4	FBT6-T45E-MBT4-	27.0	20.6	15.0	7.1	24.2	14.2	5600 (385)	2800 (192)
3/8	3/8	FBT6-T45E-MBT6-	27.0	20.6	15.0	9.7	24.2	14.2	5600 (385)	2800 (192)
3/8	1/2	FBT6-T45E-MBT8-	27.0	20.6	15.0	11.9	29.0	19.1	5600 (385)	2800 (192)
3/8	3/4	FBT6-T45E-MBT12-	27.0	27.0	15.0	11.9	30.5	19.1	7300 (502)	3600 (248)
3/8	1	FBT6-T45E-MBT16-	32.0	34.9	15.0	11.9	37.6	23.9	5300 (365)	2600 (179)
1/2	1/4	FBT8-T45E-MBT4-	32.0	25.4	19.8	7.1	25.2	14.2	5600 (385)	2800 (192)
1/2	3/8	FBT8-T45E-MBT6-	32.0	25.4	19.8	9.7	25.2	14.2	5600 (385)	2800 (192)
1/2	1/2	FBT8-T45E-MBT8-	32.0	25.4	19.8	11.9	32.0	19.1	5600 (385)	2800 (192)
1/2	3/4	FBT8-T45E-MBT12-	32.5	27.0	19.8	15.7	30.5	19.1	5600 (385)	2800 (192)
1/2	1	FBT8-T45E-MBT16-	37.6	34.9	19.8	15.7	37.6	23.9	5300 (365)	2600 (179)
3/4	3/4	FBT12-T45E-MBT12-	34.5	31.8	20.6	15.7	34.5	19.1	5100 (351)	2500 (172)
3/4	1	FBT12-T45E-MBT16-	37.6	34.9	20.6	22.4	37.6	23.9	5100 (351)	2500 (172)
1	1	FBT16-T45E-MBT16-	46.0	42.9	25.4	22.4	46.0	23.9	5300 (365)	2600 (179)
1 1/4	1 1/4	FBT20-T45E-MBT20-	50.8	50.8	25.4	31.8	50.8	23.9	3100 (213)	1600 (110)

Female Elbows

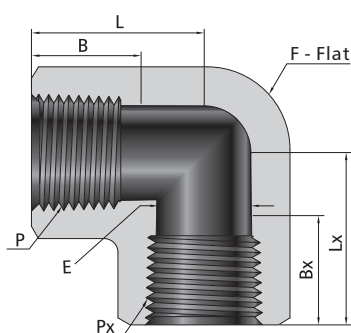

Female FNPT Threads

P-FNPT Size	Px-FNPT Size	Basic Ordering Number	Dimension, mm						Working Pressure psig (bar)	
			L	F	B	E	Lx	Bx	316 SS, Steel	Brass
1/16	1/16	FNPT1-TFE-FNPT1-	21.8	11.1	9.9	4.8	21.8	9.9	6700 (460)	3300 (227)
1/8	1/16	FNPT2-TFE-FNPT1-	26.4	12.7	10.4	4.8	26.4	9.9	6200 (427)	3100 (213)
1/8	1/8	FNPT2-TFE-FNPT2-	26.4	12.7	10.4	8.6	26.4	10.4	6200 (427)	3100 (213)
1/4	1/8	FNPT4-TFE-FNPT2-	29.7	17.5	15.0	7.1	29.7	10.4	7200 (496)	3600 (248)
1/4	1/4	FNPT4-TFE-FNPT4-	29.7	17.5	15.0	11.4	29.7	15.0	7200 (496)	3600 (248)
3/8	3/8	FNPT6-TFE-FNPT6-	36.1	20.6	15.0	15.0	36.1	15.0	5600 (385)	2800 (192)
1/2	1/2	FNPT8-TFE-FNPT8-	39.6	25.4	19.8	18.5	39.6	19.8	5600 (385)	2800 (192)
3/4	3/4	FNPT12-TFE-FNPT12-	48.8	31.8	20.6	23.9	48.8	20.6	5100 (351)	2500 (172)
1	1	FNPT16-TFE-FNPT16-	48.5	42.9	25.4	29.7	48.5	25.4	6400 (440)	3200 (220)
1 1/4	1 1/4	FNPT20-TFE-FNPT20-	59.8	50.8	25.4	27.7	50.8	25.4	3100 (213)	1600 (110)
1 1/2	1 1/2	FNPT24-TFE-FNPT24-	65.0	63.5	27.7	34.0	52.8	27.7	5100 (351)	2500 (172)

Heavy-Wall Female NPT Threads

1/4	1/4	FNPT4-TFE1-FNPT4-	39.6	25.4	15.0	11.4	29.7	15.0	10000 (689)	/
1/2	1/2	FNPT8-TFE1-FNPT8-	50.0	42.9	19.8	18.5	39.6	19.8	10000 (689)	/

Female ISO Tapered Threads

P-BSPT Size	Px-BSPT Size	Basic Ordering Number	Dimension, mm						Working Pressure psig (bar)	
			L	F	B	E	Lx	Bx	316 SS, Steel	Brass
1/16	1/16	FBT1-TFE-FBT1-	21.8	11.1	9.9	4.8	21.6	9.9	6700 (460)	3300 (227)
1/8	1/16	FBT2-TFE-FBT1-	16.8	12.7	10.4	4.8	16.8	9.9	6200 (427)	3100 (213)
1/8	1/8	FBT2-TFE-FBT2-	26.4	12.7	10.4	7.1	26.4	10.4	6200 (427)	3100 (213)
1/4	1/8	FBT4-TFE-FBT2-	29.7	17.5	15.0	7.1	29.7	10.4	7200 (496)	3600 (248)
1/4	1/4	FBT4-TFE-FBT4-	29.7	17.5	15.0	10.4	29.7	15.0	7200 (496)	3600 (248)
3/8	3/8	FBT6-TFE-FBT6-	36.1	20.6	15.0	12.7	36.1	15.0	5600 (385)	2800 (192)
1/2	1/2	FBT8-TFE-FBT8-	39.6	25.4	19.8	15.7	39.6	19.8	5600 (385)	2800 (192)
3/4	3/4	FBT12-TFE-FBT12-	48.8	31.8	20.6	22.4	48.8	20.6	5100 (351)	2500 (172)
1	1	FBT16-TFE-FBT16-	48.5	42.9	25.4	22.4	48.5	25.4	6400 (440)	3200 (220)
1 1/4	1 1/4	FBT20-TFE-FBT20-	59.8	50.8	25.4	27.7	50.8	25.4	3100 (213)	1600 (110)
1 1/2	1 1/2	FBT24-TFE-FBT24-	65.0	63.5	27.7	34.0	52.8	27.7	5100 (351)	2500 (172)

45° Female Elbows

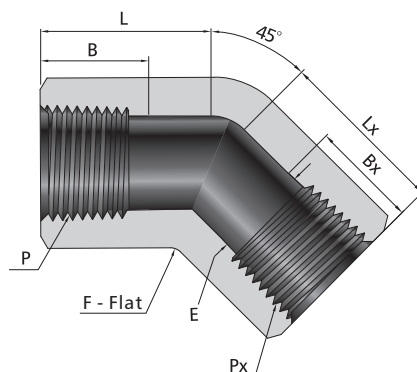

Female NPT Threads

P-NPT Size	Px-NPT Size	Basic Ordering Number	Dimension, mm						Working Pressure psig (bar)	
			L	F	B	E	Lx	Bx	316 SS, Steel	Brass
1/16	1/16	FNPT1-T45FE-FNPT1-	16.8	11.1	9.9	4.8	16.8	9.9	6700 (460)	3300 (227)
1/8	1/16	FNPT2-T45FE-FNPT1-	20.2	12.7	10.4	4.8	20.2	9.9	6200 (427)	3100 (213)
1/8	1/8	FNPT2-T45FE-FNPT2-	20.2	12.7	10.4	7.1	20.2	10.4	6200 (427)	3100 (213)
1/4	1/8	FNPT4-T45FE-FNPT2-	25.4	17.5	15.0	7.1	25.4	10.4	7200 (496)	3600 (248)
1/4	1/4	FNPT4-T45FE-FNPT4-	25.4	17.5	15.0	10.4	25.4	15.0	7200 (496)	3600 (248)
3/8	3/8	FNPT6-T45FE-FNPT6-	27.0	20.6	15.0	12.7	27.0	15.0	5600 (385)	2800 (192)
1/2	1/2	FNPT8-T45FE-FNPT8-	32.0	25.4	19.8	15.7	32.0	19.8	5600 (385)	2800 (192)
3/4	3/4	FNPT12-T45FE-FNPT12-	34.5	31.8	20.6	22.4	34.5	20.6	5100 (351)	2500 (172)
1	1	FNPT16-T45FE-FNPT16-	46.0	42.9	25.4	22.4	46.0	25.4	6400 (440)	3200 (220)
1 1/4	1 1/4	FNPT20-T45FE-FNPT20-	43.2	50.8	25.4	27.7	43.2	25.4	3100 (213)	1600 (110)
1 1/2	1 1/2	FNPT24-T45FE-FNPT24-	46.0	63.5	27.7	34.0	46.0	27.7	5100 (351)	2500 (172)

Female ISO Tapered Pipe Threads

P-BSPT Size	Px-BSPT Size	Basic Ordering Number	Dimension, mm						Working Pressure psig (bar)	
			L	F	B	E	Lx	Bx	316 SS, Steel	Brass
1/16	1/16	FBT1-T45FE-FBT1-	16.8	11.1	9.9	4.8	16.8	9.9	6700 (460)	3300 (227)
1/8	1/16	FBT2-T45FE-FBT1-	20.2	12.7	10.4	4.8	20.2	9.9	6200 (427)	3100 (213)
1/8	1/8	FBT2-T45FE-FBT2-	20.2	12.7	10.4	7.1	20.2	10.4	6200 (427)	3100 (213)
1/4	1/8	FBT4-T45FE-FBT2-	25.4	17.5	15.0	7.1	25.4	10.4	7200 (496)	3600 (248)
1/4	1/4	FBT4-T45FE-FBT4-	25.4	17.5	15.0	10.4	25.4	15.0	7200 (496)	3600 (248)
3/8	3/8	FBT6-T45FE-FBT6-	27.0	20.6	15.0	12.7	27.0	15.0	5600 (385)	2800 (192)
1/2	1/2	FBT8-T45FE-FBT8-	32.0	25.4	19.8	15.7	32.0	19.8	5600 (385)	2800 (192)
3/4	3/4	FBT12-T45FE-FBT12-	34.5	31.8	20.6	22.4	34.5	20.6	5100 (351)	2500 (172)
1	1	FBT16-T45FE-FBT16-	46.0	42.9	25.4	22.4	46.0	25.4	6400 (440)	3200 (220)
1 1/4	1 1/4	FBT20-T45FE-FBT20-	43.2	50.8	25.4	27.7	43.2	25.4	3100 (213)	1600 (110)
1 1/2	1 1/2	FBT24-T45FE-FBT24-	46.0	63.5	27.7	34.0	46.0	27.7	5100 (351)	2500 (172)

Male Tees

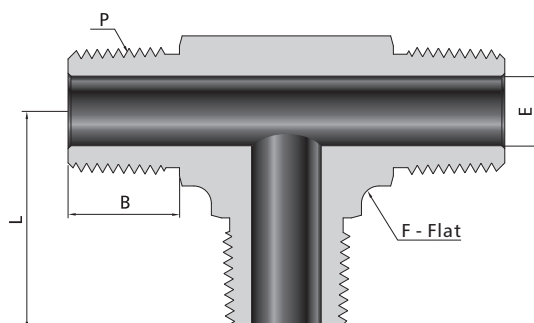

Male NPT Threads

P-NPT Size	Basic Ordering Number	Dimension, mm				Working Pressure psig (bar)	
		L	F	B	E	316 SS, Steel	Brass
1/16	NPT1-TMT-NPT1-NPT1-	18.3	9.5	9.7	3.0	11000 (757)	5500 (378)
1/8	NPT2-TMT-NPT2-NPT2-	22.4	11.1	9.7	4.8	10000 (689)	5000 (344)
1/4	NPT4-TMT-NPT4-NPT4-	26.7	12.7	14.2	7.1	8000 (551)	4000 (275)
3/8	NPT6-TMT-NPT6-NPT6-	29.7	17.5	14.2	9.6	7800 (537)	3900 (268)
1/2	NPT8-TMT-NPT8-NPT8-	36.8	20.6	19.1	11.9	7700 (530)	3800 (261)
3/4	NPT12-TMT-NPT12-NPT12-	42.4	27.0	19.1	15.7	7300 (502)	3600 (248)
1	NPT16-TMT-NPT16-NPT16-	49.3	34.9	23.9	22.4	5300 (365)	2600 (179)
1 1/4	NPT20-TMT-NPT20-NPT20-	56.4	42.9	23.9	27.7	6000 (410)	3000 (200)
1 1/2	NPT24-TMT-NPT24-NPT24-	67.1	47.6	26.2	34.0	5000 (344)	2500 (172)

Male ISO Tapered Threads

P-BSPT Size	Basic Ordering Number	Dimension, mm				Working Pressure psig (bar)	
		L	F	B	E	316 SS, Steel	Brass
1/16	MBT1-TMT-MBT1-MBT1-	18.3	9.5	9.7	3.0	11000 (757)	5500 (378)
1/8	MBT2-TMT-MBT2-MBT2-	22.4	11.1	9.7	4.8	10000 (689)	5000 (344)
1/4	MBT4-TMT-MBT4-MBT4-	26.7	12.7	14.2	7.1	8000 (551)	4000 (275)
3/8	MBT6-TMT-MBT6-MBT6-	29.7	17.5	14.2	9.7	7800 (537)	3900 (268)
1/2	MBT8-TMT-MBT8-MBT8-	36.8	20.6	19.1	11.9	7700 (530)	3800 (261)
3/4	MBT12-TMT-MBT12-MBT12-	42.4	27.0	19.1	15.7	7300 (502)	3600 (248)
1	MBT16-TMT-MBT16-MBT16-	49.3	34.9	23.9	22.4	5300 (365)	2600 (179)
1 1/4	MBT20-TMT-MBT20-MBT20-	56.4	42.9	23.9	27.7	6000 (410)	3000 (200)
1 1/2	MBT24-TMT-MBT24-MBT24-	67.1	47.6	26.2	34.0	5000 (344)	2500 (172)

Female Branch Tees

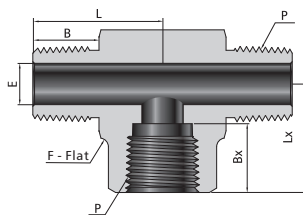

NPT Threads

P-NPT Size	Basic Ordering Number	Dimension, mm						Working Pressure psig (bar)	
		L	F	E	B	Lx	Bx	316 SS, Steel	Brass
1/16	NPT1-TFBT-NPT1-FNPT1-	18.3	11.1	3.0	9.7	21.8	9.9	9200 (633)	4600 (316)
1/8	NPT2-TFBT-NPT2-FNPT2-	22.1	12.7	4.8	9.7	26.4	10.4	6200 (427)	3100 (213)
1/4	NPT4-TFBT-NPT4-FNPT4-	29.7	17.5	7.1	14.2	29.7	15.0	7200 (496)	3600 (248)
3/8	NPT6-TFBT-NPT6-FNPT6-	32.0	20.6	9.7	14.2	36.1	15.0	5600 (385)	2800 (192)
1/2	NPT8-TFBT-NPT8-FNPT8-	39.6	25.4	11.9	19.1	39.6	19.8	5600 (385)	2800 (192)
3/4	NPT12-TFBT-NPT12-FNPT12-	42.4	31.8	15.7	19.1	48.8	20.6	5100 (351)	2500 (172)
1	NPT16-TFBT-NPT16-FNPT16-	49.3	42.9	22.4	23.9	48.5	25.4	5300 (365)	2600 (179)

ISO Tapered Pipe Threads

P-BSPT Size	Basic Ordering Number	Dimension, mm						Working Pressure psig (bar)	
		L	F	E	B	Lx	Bx	316 SS, Steel	Brass
1/16	MBT1-TFBT-MBT1-FBT1-	18.3	11.1	3.0	9.7	21.8	9.9	9200 (633)	4600 (316)
1/8	MBT2-TFBT-MBT2-FBT2-	22.1	12.7	4.8	9.7	26.4	10.4	6200 (427)	3100 (213)
1/4	MBT4-TFBT-MBT4-FBT4-	29.7	17.5	7.1	14.2	29.7	15.0	7200 (496)	3600 (248)
3/8	MBT6-TFBT-MBT6-FBT6-	32.0	20.6	9.7	14.2	36.1	15.0	5600 (385)	2800 (192)
1/2	MBT8-TFBT-MBT8-FBT8-	39.6	25.4	11.9	19.1	39.6	19.8	5600 (385)	2800 (192)
3/4	MBT12-TFBT-MBT12-FBT12-	42.4	31.8	15.7	19.1	48.8	20.6	5100 (351)	2500 (172)
1	MBT16-TFBT-MBT16-FBT16-	49.3	42.9	22.4	23.9	48.5	25.4	5300 (365)	2600 (179)

Female Run Tees

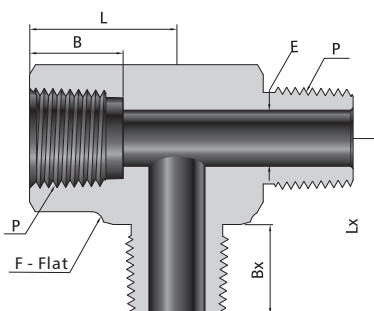

NPT Threads

P-NPT Size	Basic Ordering Number	Dimension, mm						Working Pressure psig (bar)	
		L	F	E	B	Lx	Bx	316 SS, Steel	Brass
1/16	FNPT1-TFRT-NPT1-NPT1-	21.8	11.1	3.0	9.9	18.3	9.7	9200 (633)	4600 (316)
1/8	FNPT2-TFRT-NPT2-NPT2-	26.4	12.7	4.8	10.4	22.1	9.7	6200 (427)	3100 (213)
1/4	FNPT4-TFRT-NPT4-NPT4-	29.7	17.5	7.1	15.0	29.7	14.2	7200 (496)	3600 (248)
3/8	FNPT6-TFRT-NPT6-NPT6-	36.1	20.6	9.7	15.0	32.0	14.2	5600 (385)	2800 (192)
1/2	FNPT8-TFRT-NPT8-NPT8-	39.6	25.4	11.9	19.8	39.6	19.1	5600 (385)	2800 (192)
3/4	FNPT12-TFRT-NPT12-NPT12-	48.8	31.8	15.7	20.6	42.4	19.1	5100 (351)	2500 (172)
1	FNPT16-TFRT-NPT16-NPT16-	48.5	42.9	22.4	25.4	49.3	23.9	5300 (365)	2600 (179)

ISO Tapered Threads

P-BSPT Size	Basic Ordering Number	Dimension, mm						Working Pressure psig (bar)	
		L	F	E	B	Lx	Bx	316 SS, Steel	Brass
1/16	FBT1-TFRT-MBT1-MBT1-	21.8	11.1	3.0	9.9	18.3	9.7	9200 (633)	4600 (316)
1/8	FBT2-TFRT-MBT2-MBT2-	26.4	12.7	4.8	10.4	22.1	9.7	6200 (427)	3100 (213)
1/4	FBT4-TFRT-MBT4-MBT4-	29.7	17.5	7.1	15.0	29.7	14.2	7200 (496)	3600 (248)
3/8	FBT6-TFRT-MBT6-MBT6-	36.1	20.6	9.7	15.0	32.0	14.2	5600 (385)	2800 (192)
1/2	FBT8-TFRT-MBT8-MBT8-	39.6	25.4	11.9	19.8	39.6	19.1	5600 (385)	2800 (192)
3/4	FBT12-TFRT-MBT12-MBT12-	48.8	31.8	15.7	20.6	42.4	19.1	5100 (351)	2500 (172)
1	FBT16-TFRT-MBT16-MBT16-	48.5	42.9	22.4	25.4	49.3	23.9	5300 (365)	2600 (179)

Male Street Tees

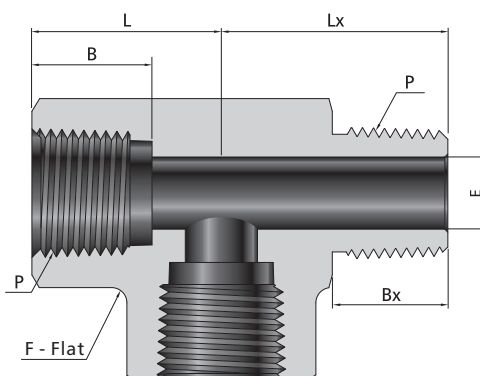

NPT Threads

P-NPT Size	Basic Ordering Number	Dimension, mm						Working Pressure psig (bar)	
		L	F	E	B	Lx	Bx	316 SS, Steel	Brass
1/16	FNPT1-TMST-NPT1-FNPT1-	21.8	11.1	3.0	9.9	18.3	9.7	9200 (633)	4600 (316)
1/8	FNPT2-TMST-NPT2-FNPT2-	26.4	12.7	4.8	10.4	22.1	9.7	6200 (427)	3100 (213)
1/4	FNPT4-TMST-NPT4-FNPT4-	29.7	17.5	7.1	15.0	29.7	14.2	7200 (496)	3600 (248)
3/8	FNPT6-TMST-NPT6-FNPT6-	36.1	20.6	9.6	15.0	32.0	14.2	5600 (385)	2800 (192)
1/2	FNPT8-TMST-NPT8-FNPT8-	39.6	25.4	11.9	19.8	39.6	19.1	5600 (385)	2800 (192)
3/4	FNPT12-TMST-NPT12-FNPT12-	48.8	31.8	15.7	20.6	42.4	19.1	5100 (351)	2500 (172)
1	FNPT16-TMST-NPT16-FNPT16-	48.5	42.9	22.4	25.4	49.3	23.9	5300 (365)	2600 (179)

ISO Tapered Pipe Threads

P-BSPT Size	Basic Ordering Number	Dimension, mm						Working Pressure psig (bar)	
		L	F	E	B	Lx	Bx	316 SS, Steel	Brass
1/16	FBT1-TMST-MBT1-FBT1-	21.8	11.1	3.0	9.9	18.3	9.7	9200 (633)	4600 (316)
1/8	FBT2-TMST-MBT2-FBT2-	26.4	12.7	4.8	10.4	22.1	9.7	6200 (427)	3100 (213)
1/4	FBT4-TMST-MBT4-FBT4-	29.7	17.5	7.1	15.0	29.7	14.2	7200 (496)	3600 (248)
3/8	FBT6-TMST-MBT6-FBT6-	36.1	20.6	9.7	15.0	32.0	14.2	5600 (385)	2800 (192)
1/2	FBT8-TMST-MBT8-FBT8-	39.6	25.4	11.9	19.8	39.6	19.1	5600 (385)	2800 (192)
3/4	FBT12-TMST-MBT12-FBT12-	48.8	31.8	15.7	20.6	42.4	19.1	5100 (351)	2500 (172)
1	FBT16-TMST-MBT16-FBT16-	48.5	42.9	22.4	25.4	49.3	23.9	5300 (365)	2600 (179)

Male Branch Tees

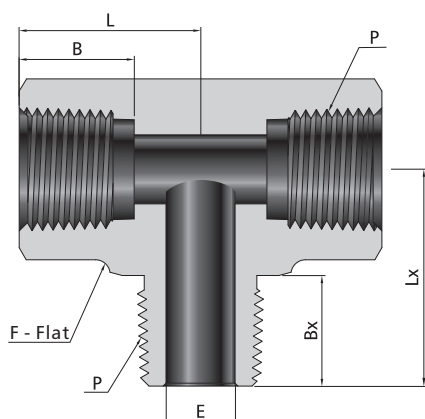

NPT Threads

P-NPT Size	Basic Ordering Number	Dimension, mm						Working Pressure psig (bar)	
		L	F	E	B	Lx	Bx	316 SS, Steel	Brass
1/16	FNPT1-TMBT-FNPT1-NPT1-	21.8	11.1	3.0	9.9	18.3	9.7	9200 (633)	4600 (316)
1/8	FNPT2-TMBT-FNPT2-NPT2-	26.4	12.7	4.8	10.4	22.1	9.7	6200 (427)	3100 (213)
1/4	FNPT4-TMBT-FNPT4-NPT4-	29.7	17.5	7.1	15.0	29.7	14.2	7200 (496)	3600 (248)
3/8	FNPT6-TMBT-FNPT6-NPT6-	36.1	20.6	9.6	15.0	32.0	14.2	5600 (385)	2800 (192)
1/2	FNPT8-TMBT-FNPT8-NPT8-	39.6	25.4	11.9	19.8	39.6	19.1	5600 (385)	2800 (192)
3/4	FNPT12-TMBT-FNPT12-NPT12-	48.8	31.8	15.7	20.6	42.4	19.1	5100 (351)	2500 (172)
1	FNPT16-TMBT-FNPT16-NPT16-	48.5	42.9	22.4	25.4	49.3	23.9	5300 (365)	2600 (179)

ISO Tapered Pipe Threads

P-BSPT Size	Basic Ordering Number	Dimension, mm						Working Pressure psig (bar)	
		L	F	E	B	Lx	Bx	316 SS, Steel	Brass
1/16	FBT1-TMBT-FBT1-MBT1-	21.8	11.1	3.0	9.9	18.3	9.7	9200 (633)	4600 (316)
1/8	FBT2-TMBT-FBT2-MBT2-	26.4	12.7	4.8	10.4	22.1	9.7	6200 (427)	3100 (213)
1/4	FBT4-TMBT-FBT4-MBT4-	29.7	17.5	7.1	15.0	29.7	14.2	7200 (496)	3600 (248)
3/8	FBT6-TMBT-FBT6-MBT6-	36.1	20.6	9.7	15.0	32.0	14.2	5600 (385)	2800 (192)
1/2	FBT8-TMBT-FBT8-MBT8-	39.6	25.4	11.9	19.8	39.6	19.1	5600 (385)	2800 (192)
3/4	FBT12-TMBT-FBT12-MBT12-	48.8	31.8	15.7	20.6	42.4	19.1	5100 (351)	2500 (172)
1	FBT16-TMBT-FBT16-MBT16-	48.5	42.9	22.4	25.4	49.3	23.9	5300 (365)	2600 (179)

Female Tees

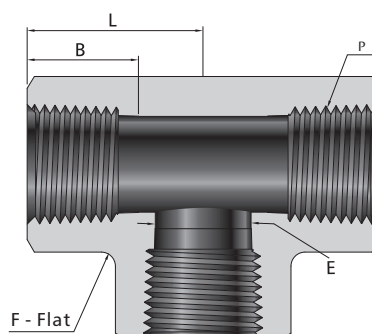

Female NPT Threads

P-NPT Size	Basic Ordering Number	Dimension, mm				Working Pressure psig (bar)	
		L	F	E	B	316 SS, Steel	Brass
1/16	FNPT1-TFT-FNPT1-FNPT1-	21.8	11.1	4.8	9.9	6700 (460)	3300 (227)
1/8	FNPT2-TFT-FNPT2-FNPT2-	26.4	12.7	8.6	10.4	6200 (427)	3100 (213)
1/4	FNPT4-TFT-FNPT4-FNPT4-	29.7	17.5	11.4	15.0	7200 (496)	3600 (248)
3/8	FNPT6-TFT-FNPT6-FNPT6-	36.1	20.6	15.0	15.0	5600 (385)	2800 (192)
1/2	FNPT8-TFT-FNPT8-FNPT8-	39.6	25.4	18.5	19.8	5600 (385)	2800 (192)
3/4	FNPT12-TFT-FNPT12-FNPT12-	48.8	31.8	23.9	20.6	5100 (351)	2500 (172)
1	FNPT16-TFT-FNPT16-FNPT16-	48.5	42.9	29.7	25.4	6400 (440)	3200 (220)
1 1/4	FNPT20-TFT-FNPT20-FNPT20-	59.8	50.8	37.2	25.4	3100 (213)	1600 (110)
1 1/2	FNPT24-TFT-FNPT24-FNPT24-	65.0	63.5	43.3	27.7	5100 (351)	2500 (172)

Heavy-Wall Female NPT Threads

1/4	FNPT4-TFT1-FNPT4-FNPT4-	39.6	25.4	11.4	15.0	10000 (689)	/
1/2	FNPT8-TFT1-FNPT8-FNPT8-	50.0	27.0	18.5	19.8	10000 (689)	/

Female ISO Tapered Pipe Threads

P-BSPT Size	Basic Ordering Number	Dimension, mm				Working Pressure psig (bar)	
		L	F	E	B	316 SS, Steel	Brass
1/16	FBT1-TFT-FBT1-FBT1-	21.8	11.1	4.8	9.9	6700 (460)	3300 (227)
1/8	FBT2-TFT-FBT2-FBT2-	26.4	12.7	8.6	10.4	6200 (427)	3100 (213)
1/4	FBT4-TFT-FBT4-FBT4-	29.7	17.5	11.2	15.0	7200 (496)	3600 (248)
3/8	FBT6-TFT-FBT6-FBT6-	36.1	20.6	14.7	15.0	5600 (385)	2800 (192)
1/2	FBT8-TFT-FBT8-FBT8-	39.6	25.4	18.3	19.8	5600 (385)	2800 (192)
3/4	FBT12-TFT-FBT12-FBT12-	48.8	31.8	23.9	20.6	5100 (351)	2500 (172)
1	FBT16-TFT-FBT16-FBT16-	48.5	42.9	29.7	25.4	6400 (440)	3200 (220)
1 1/4	FBT20-TFT-FBT20-FBT20-	59.8	50.8	37.2	25.4	3100 (213)	1600 (110)
1 1/2	FBT24-TFT-FBT24-FBT24-	65.0	63.5	43.3	27.7	5100 (351)	2500 (172)

Female Crosses

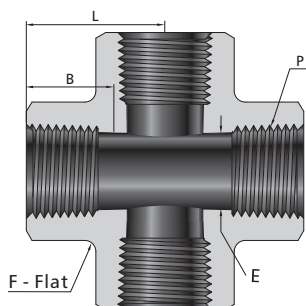

Female NPT Threads

P-NPT Size	Basic Ordering Number	Dimension, mm				Working Pressure psig (bar)	
		L	F	E	B	316 SS, Steel	Brass
1/16	FNPT1-TFC-FNPT1-FNPT1-FNPT1-	21.8	11.1	4.8	9.9	6700 (460)	3300 (227)
1/8	FNPT2-TFC-FNPT2-FNPT2-FNPT2-	26.4	12.7	8.6	10.4	6200 (427)	3100 (213)
1/4	FNPT4-TFC-FNPT4-FNPT4-FNPT4-	29.7	17.5	11.4	15.0	7200 (496)	3600 (248)
3/8	FNPT6-TFC-FNPT6-FNPT6-FNPT6-	36.1	20.6	15.0	15.0	5600 (385)	2800 (192)
1/2	FNPT8-TFC-FNPT8-FNPT8-FNPT8-	39.6	25.4	18.5	19.8	5600 (385)	2800 (192)
3/4	FNPT12-TFC-FNPT12-FNPT12-FNPT12-	48.8	31.8	23.9	20.6	5100 (351)	2500 (172)
1	FNPT16-TFC-FNPT16-FNPT16-FNPT16-	48.5	42.9	29.7	25.4	6400 (440)	3200 (220)

Female ISO Tapered Threads

P-BSPT Size	Basic Ordering Number	Dimension, mm				Working Pressure psig (bar)	
		L	F	E	B	316 SS, Steel	Brass
1/16	FBT1-TFC-FBT1-FBT1-FBT1-	21.8	11.1	4.8	9.9	6700 (460)	3300 (227)
1/8	FBT2-TFC-FBT2-FBT2-FBT2-	26.4	12.7	8.6	10.4	6200 (427)	3100 (213)
1/4	FBT4-TFC-FBT4-FBT4-FBT4-	29.7	17.5	11.4	15.0	7200 (496)	3600 (248)
3/8	FBT6-TFC-FBT6-FBT6-FBT6-	36.1	20.6	15.0	15.0	5600 (385)	2800 (192)
1/2	FBT8-TFC-FBT8-FBT8-FBT8-	39.6	25.4	18.5	19.8	5600 (385)	2800 (192)
3/4	FBT12-TFC-FBT12-FBT12-FBT12-	48.8	31.8	23.9	20.6	5100 (351)	2500 (172)
1	FBT16-TFC-FBT16-FBT16-FBT16-	48.5	42.9	29.7	25.4	6400 (440)	3200 (220)

Pipe to Pipe Unions

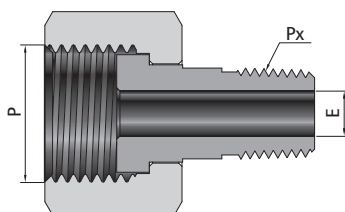

Metric Thread

P-Metric Thread Size	Px-NPT Size	Basic Ordering Number	Dimension, mm	Working Pressure psig (bar) 316 SS, Steel
			E	
M20 x 1.5	1/8	FMS20-TPU-NPT2-	4.8	4500 (310)
M20 x 1.5	1/4	FMS20-TPU-NPT4-	7.1	4500 (310)

NPT Threads

Metric Thread

P-Metric Thread Size	Px-BSPT Size	Basic Ordering Number	Dimension, mm	Working Pressure psig (bar) 316 SS, Steel
			E	
M20 x 1.5	1/8	FMS20-TPU-MBT2-	4.8	4500 (310)
M20 x 1.5	1/4	FMS20-TPU-MBT4-	7.1	4500 (310)

ISO Tapered Pipe Threads

ISO Parallel Thread

P-BG Size	Px-NPT Size	Basic Ordering Number	Dimension, mm	Working Pressure psig (bar) 316 SS, Steel
			E	
1/2	1/8	FBP8-TPU-NPT2	4.8	4900 (337)
1/2	1/4	FBP8-TPU-NPT4	7.1	4900 (337)

Union Ball Joints

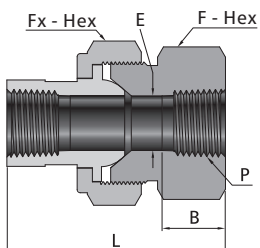

Female NPT Threads

P-NPT Size	Basic Ordering Number	Dimension, mm					Working Pressure psig (bar) 316 SS, Steel
		L	F	Fx	B	E	
1/8	FNPT2-UBJ-FNPT2-	46.0	23.8	28.6	10.4	6.8	8400 (578)
1/4	FNPT4-UBJ-FNPT4-	59.4	30.2	34.9	15.0	9.1	6600 (454)
3/8	FNPT6-UBJ-FNPT6-	63.5	33.3	38.1	15.0	13.2	5300 (365)
1/2	FNPT8-UBJ-FNPT8-	68.3	41.3	44.5	19.8	15.7	6000 (410)
3/4	FNPT12-UBJ-FNPT12-	79.2	47.6	54.0	20.6	22.4	4600 (316)
1	FNPT16-UBJ-FNPT16-	90.4	60.3	63.5	25.4	26.2	6800 (468)

Female ISO Tapered Threads

P-BSPT Size	Basic Ordering Number	Dimension, mm					Working Pressure psig (bar) 316 SS, Steel
		L	F	Fx	B	E	
1/8	FBT2-UBJ-FBT2-	46.0	23.8	28.6	10.4	6.8	8400 (578)
1/4	FBT4-UBJ-FBT4-	59.4	30.2	34.9	15.0	9.1	6600 (454)
3/8	FBT6-UBJ-FBT6-	63.5	33.3	38.1	15.0	13.2	5300 (365)
1/2	FBT8-UBJ-FBT8-	68.3	41.3	44.5	19.8	15.7	6000 (410)
3/4	FBT12-UBJ-FBT12-	79.2	47.6	54.0	20.6	22.4	4600 (316)
1	FBT16-UBJ-FBT16-	90.4	60.3	63.5	25.4	26.2	6800 (468)

Male Pipe to Tube Butt Weld (UGJ)

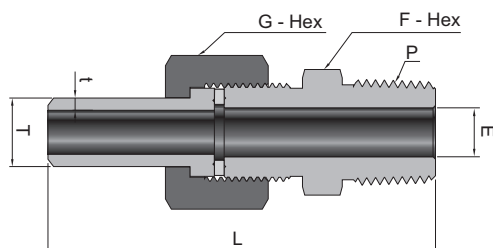

NPT Thread

Metric Tube

P-NPT Size	T-Tube O.D. (mm)	t-Wall Thickness (mm)	Basic Ordering Number	Dimension, mm (in.)				Working Pressure psig (bar)
				L	F	G	E	
1/8	14	2.5	MBW14-UGJ-NPT2	69.0 (2.72)	19.0 (0.75)	22.0 (0.87)	4.8 (0.19)	6280 (433)
1/4	6	1.8	MBW6-UGJ-NPT4	60.0 (2.36)	14.0 (0.55)	14.0 (0.55)	3.0 (0.12)	8240 (566)
1/4	8	1.8	MBW8-UGJ-NPT4	73.2 (2.88)	14.0 (0.55)	16.0 (0.63)	4.0 (0.16)	8240 (566)
1/4	10	2.2	MBW10-UGJ-NPT4	73.2 (2.88)	15.0 (0.59)	18.0 (0.71)	6.0 (0.24)	8160 (563)
1/4	12	2.2	MBW12-UGJ-NPT4	73.2 (2.88)	18.0 (0.71)	22.0 (0.87)	7.0 (0.28)	6470 (446)
1/4	14	2.5	MBW14-UGJ-NPT4	73.2 (2.88)	19.0 (0.75)	22.0 (0.87)	7.1 (0.28)	6280 (433)
1/4	16	2.8	MBW16-UGJ-NPT4	73.2 (2.88)	22.0 (0.87)	25.0 (0.98)	7.1 (0.28)	6140 (423)
1/4	18	2.8	MBW18-UGJ-NPT4	74.2 (2.92)	24.0 (0.94)	27.0 (1.06)	7.1 (0.28)	5670 (392)
3/8	14	2.5	MBW14-UGJ-NPT6	73.2 (2.88)	19.0 (0.75)	22.0 (0.87)	9.7 (0.38)	6280 (433)
1/2	12	2.2	MBW12-UGJ-NPT8	78.0 (3.07)	18.0 (0.71)	22.0 (0.87)	7.0 (0.28)	6470 (446)
1/2	14	2.5	MBW14-UGJ-NPT8	78.0 (3.07)	19.0 (0.75)	22.0 (0.87)	9.0 (0.35)	6280 (433)
1/2	16	2.8	MBW16-UGJ-NPT8	78.0 (3.07)	22.0 (0.87)	25.0 (0.98)	10.0 (0.39)	6140 (423)
1/2	22	3.0	MBW22-UGJ-NPT8	82.0 (3.23)	30.0 (1.18)	32.0 (1.26)	11.9 (0.47)	4620 (319)
1/2	25	2.8	MBW25-UGJ-NPT8	86.0 (3.39)	32.0 (1.26)	35.0 (1.38)	11.9 (0.47)	4730 (326)
1	25	3.5	MBW25-UGJ-NPT16	103.0 (4.06)	35.0 (1.38)	35.0 (1.38)	17.0 (0.67)	4730 (326)

Male Pipe to Tube Butt Weld (UOJ)

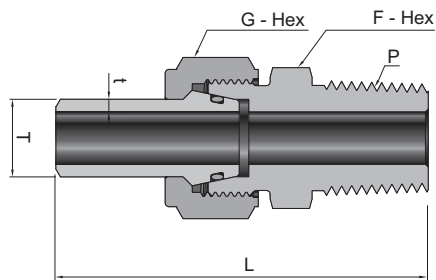

NPT Thread				Metric Tube				Working Pressure psig (bar)
P-NPT Size	T-Tube O.D. (mm)	t-Wall Thickness (mm)	Basic Ordering Number	Dimension, mm (in.)				
				L	F	G	E	
1/8	14	2.5	MBW14-UOJ-NPT2	69.0 (2.72)	19.0 (0.75)	22.0 (0.87)	4.8 (0.19)	6280 (433)
1/4	6	1.8	MBW6-UOJ-NPT4	60.0 (2.36)	14.0 (0.55)	14.0 (0.55)	3.0 (0.12)	8240 (566)
1/4	8	1.8	MBW8-UOJ-NPT4	73.2 (2.88)	14.0 (0.55)	16.0 (0.63)	4.0 (0.16)	8240 (566)
1/4	10	2.2	MBW10-UOJ-NPT4	73.2 (2.88)	15.0 (0.59)	18.0 (0.71)	6.0 (0.24)	8160 (563)
1/4	12	2.2	MBW12-UOJ-NPT4	73.2 (2.88)	18.0 (0.71)	22.0 (0.87)	7.0 (0.28)	6470 (446)
1/4	14	2.5	MBW14-UOJ-NPT4	73.2 (2.88)	19.0 (0.75)	22.0 (0.87)	7.1 (0.28)	6280 (433)
1/4	16	2.8	MBW16-UOJ-NPT4	73.2 (2.88)	22.0 (0.87)	25.0 (0.98)	7.1 (0.28)	6140 (423)
1/4	18	2.8	MBW18-UOJ-NPT4	74.2 (2.92)	24.0 (0.94)	27.0 (1.06)	7.1 (0.28)	5670 (392)
3/8	14	2.5	MBW14-UOJ-NPT6	73.2 (2.88)	19.0 (0.75)	22.0 (0.87)	9.7 (0.38)	6280 (433)
1/2	12	2.2	MBW12-UOJ-NPT8	78.0 (3.07)	18.0 (0.71)	22.0 (0.87)	7.0 (0.28)	6470 (446)
1/2	14	2.5	MBW14-UOJ-NPT8	78.0 (3.07)	19.0 (0.75)	22.0 (0.87)	9.0 (0.35)	6280 (433)
1/2	16	2.8	MBW16-UOJ-NPT8	78.0 (3.07)	22.0 (0.87)	25.0 (0.98)	10.0 (0.39)	6140 (423)
1/2	22	3.0	MBW22-UOJ-NPT8	82.0 (3.23)	30.0 (1.18)	32.0 (1.26)	11.9 (0.47)	4620 (319)
1/2	25	2.8	MBW25-UOJ-NPT8	86.0 (3.39)	32.0 (1.26)	35.0 (1.38)	11.9 (0.47)	4730 (326)
1	25	3.5	MBW25-UOJ-NPT16	103.0 (4.06)	35.0 (1.38)	35.0 (1.38)	17.0 (0.67)	4730 (326)

How to Order

FNPT8 — **TSE** — **NPT4** — **316**

Port 1 Type	Port 1 Size	Fitting Configuration	Port 2 Port 3 and Port 4	Material
FNPT Female NPT	2 1/8 in.	TP Pipe Plug	Same as the Port 1 or as follow :	316 316 S.S.
NPT Male NPT	4 1/4 in.	THP Hollow Hex Plug	FMS Female ISO	316L 316L S.S
NPTO O-ring with Male NPT	5 5/16-24	TCN Close Nipple	MS Male ISO (for BG)	304 304 S.S.
FBT Female BSPT	6 3/8 in. or 3/8-24	TPN Special Pipe Nipple	BPMS Male ISO (for BP)	304L 304L S.S.
MBT Male BSPT	7 7/16-20	THN Hex Nipple	BSMS Male ISO (for BS)	A20 Alloy 20
MBTO O-ring with Male BSPT	8 1/2 in. or M8 x 1	TLN Hex Long Nipple	MSO O-ring with Male ISO	A400 Alloy 400
FBP Female BSPP	9 9/16-18	TRB Reducing Bushing	FST Female SAE	A600 Alloy 600
PMBP Male BSPP (for BP)	10 M10 x 1	PC Pipe Cap	MST Male SAE (for BG)	A825 Alloy 825
MBS Male BSPP (for BS)	12 3/4 in. or M12 x 1.5 or 3/4-16	THC Hex Coupling	BPST Male SAE (for BP)	A276 Alloy C276
MBP Male BSPP (for BG)	14 M14 x 1.5 or 7/8-14	UBJ Union Ball Joints	BSST Male SAE (for BS)	DUJ7 Duplex 2507
	16 1 in. or M16 x 1.5	UGJ Union Gasket Joints	OST O-ring with Male SAE	BR Brass
	17 1 1/16-12	UOJ Union O-Ring Joints	PPT Positionable BSP Parallel Thread	CS Carbon steel
	18 M18 x 1.5	TA Adapter	PMS Positionable ISO Parallel Thread	TI Titanium
	19 1 3/16 -12	TME Male Elbow	PST Positionable SAE Parallel Thread	
	20 1 1/4 in. or M20 x 1.5	TSE Street Elbow		
	21 1 5/16 -12	T45E 45° Street Elbow		
	22 M22 x 1.5	TFE Female Elbow		
	24 1 1/2 in. or M24 x 1.5	T45FE 45° Female Elbow		
	26 1 5/8 -12	TMT Male Tee		
	27 M27 x 2	TFBT Female Branch Tee		
	30 1 7/8-12 or M30 x 2	TFRT Female Run Tee		
	32 2 in.	TMST Male Street Tee		
		TMBT Male Branch Tee		
		TFT Female Tee		
		TFC Female Cross		

