

Welded Root Valves

RTV1 Series



- ❖ Maximum working pressure up to 10000 psig (689 bar)
- ❖ Working temperature from -10°F to 1200°F (-23°C to 649°C)
- ❖ Flanged connections comply with ASME B16.5
- ❖ Stainless steel, carbon steel, Alloy 20, Alloy 400, Incoloy 825, and duplex stainless steel materials

Features

- ❖ Maximum working pressure up to 10000 psig (689 bar)
- ❖ Working temperature up to 1200°F (649°C) with Graphite packing
- ❖ Colour coded valve function identification
- ❖ Every valve is hydraulic pressure tested in accordance with EN 12266-1 and API 598. Every set is tested with nitrogen for leak-tight performance at 6000 psig
- ❖ Fire-tested design in accordance with BS 6755 part 2/API 607
- ❖ Flanged connections comply with ASME B16.5 RF and RTJ
- ❖ Pressure ratings in accordance with ASME B16.34

Needle Valve specification

- ❖ Maximum working pressure up to 10000 psig (689 bar)
- ❖ Working temperature:
 - PTFE packing: -65°F to 450°F (-54°C to 232°C)
 - Graphite packing: -65°F to 1200°F (-54°C to 649°C)
- ❖ Two-stem design: thread hardened upper stem and smooth surface hardened lower stem
- ❖ Upper stem thread lubricant is isolated from system fluid
- ❖ The nonrotating lower stem, linearly instead of helical movement, avoids galling damage to the seat and tip, as well as reduces the total friction area between the packing and the lower stem
- ❖ Stem back seating seals in fully open position
- ❖ Panel mounting is available as an option
- ❖ Double lock-pins enable steady and durable fastening of the handle
- ❖ Handle of different colors are available for option

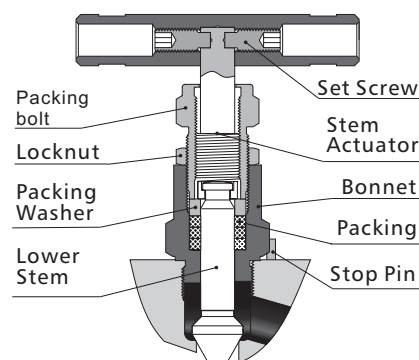

OS&Y Needle Valve specification

- ❖ Maximum working pressure is 10000 psig (689 bar)
- ❖ Working temperature are as follows:
 - PTFE: -65°F to 450°F (-54°C to 232°C)
 - Graphite: -65°F to 1200°F (-54°C to 649°C)
- ❖ Two-stem design: thread hardened upper stem and smooth surface hardened lower stem
- ❖ Upper stem thread lubricant is isolated from system fluid
- ❖ The nonrotating lower stem, linearly instead of helical movement, avoids galling damage to the seat and tip, as well as reduces the total friction area between the packing and the lower stem
- ❖ Bolted bonnet enhance strength and reliability
- ❖ Back seat design provides secondary stem sealing and prevents stem blowout
- ❖ Adjustable gland flange allows easy access to the packing gland and packing adjustment for an effective stem seal
- ❖ Investment case yoke is formed by precision casting which enhances strength and perfect stem alignment
- ❖ Two handle pins make the handle fixed firmly and lastingly

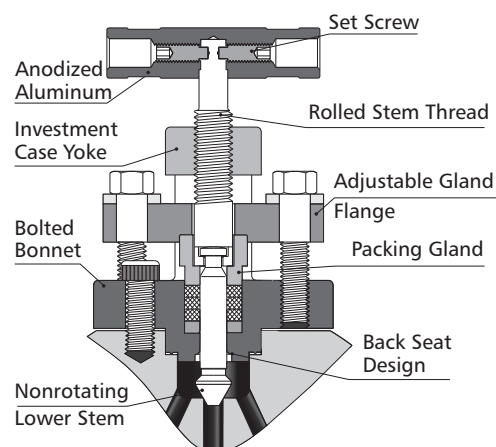

Standard Materials of Construction

Component	Body Material				
	Stainless Steel		Carbon Steel	Duplex Stainless Steel	
	Material Grade/Specification				
Body/End connector	F316 S.S. F316L S.S./A182	316 S.S. 316L S.S./A479	LF2/A350	F51/A182	S31803/A479
Needle Valve	Stem Tip	316 S.S., 316L S.S./A479			S31803/A479
	Stem				
	Bonnet				
OS&Y needle Valve	Stem Tip	316 S.S., 316L S.S./A479			S31803/A479
	Stem				
	Bonnet				
	Yoke	F316 S.S./A182			

Pressure vs. Temperature

Needle and OS&Y needle Valve

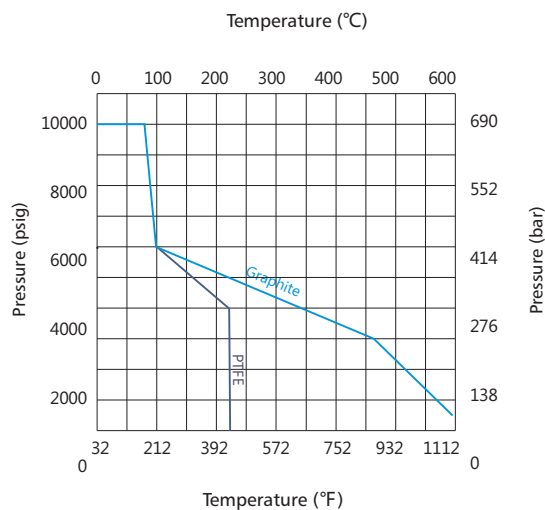

Sour Gas Service/NACE Compliant

Process interface valves for sour gas service are available. Materials are selected in accordance with NACE MR0175/ISO 15156.

Dimensions

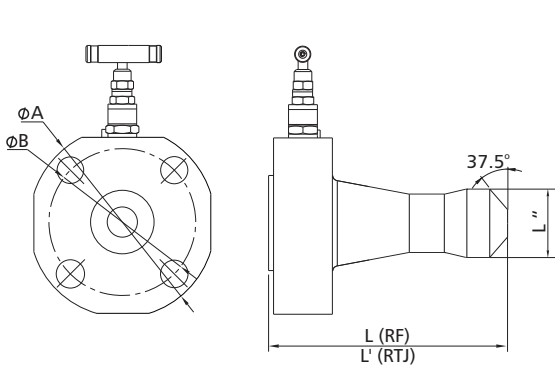
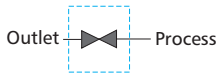

needle valve

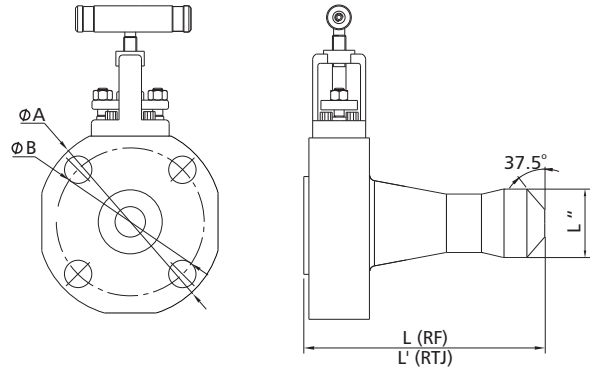

OS&Y needle valve

Flange Size	Orifice Size in. (mm)	ANSI Class	L in. (mm)	L' in. (mm)	φA in. (mm)	φB in. (mm)	L " Size
1/2 (DN 15)	0.157 (4.0)	150	2.03 (51.6)	—	3.50 (88.9)	2.38 (60.5)	2.25 (50.2)
		300		2.03 (51.6)	3.75 (95.2)	2.62 (66.5)	
		600			4.75 (120.7)	3.25 (82.5)	
		900/1500			5.25 (133.4)	3.50 (88.9)	
		2500			5.50 (139.7)	3.75 (95.2)	
3/4 (DN 20)	0.157 (4.0)	150	2.03 (51.6)	—	3.88 (98.6)	2.75 (69.8)	
		300		2.03 (51.6)	4.62 (117.3)	3.25 (82.6)	
		600			5.13 (130.3)	3.50 (88.9)	
		900/1500			5.50 (139.7)	3.75 (95.2)	
		2500			6.25 (158.8)	4.25 (108.0)	
1 (DN 25)	0.157 (4.0)	150	2.03 (51.6)	2.03 (51.6)	4.25 (108.0)	3.12 (79.2)	
		300			4.88 (124.0)	3.50 (88.9)	
		600			5.88 (149.4)	4.00 (101.6)	
		900/1500			6.25 (158.8)	4.25 (108.0)	
		2500			7.00 (177.8)	4.88 (124.0)	
1 1/2 (DN 40)	0.157 (4.0)	150	2.11 (53.5)	2.11 (53.5)	5.00 (127.0)	3.88 (98.6)	
		300			6.12 (155.5)	4.50 (114.3)	
		600			7.00 (177.8)	4.88 (124.0)	
		900/1500			8.00 (203.2)	5.75 (146.1)	
		2500			8.50 (215.9)	6.50 (165.1)	
2 (DN 50)	0.157 (4.0)	150	2.19 (55.5)	2.19 (55.5)	6.00 (152.4)	4.75 (120.7)	
		300			6.50 (165.1)	5.00 (127.0)	
		600			8.50 (215.9)	6.50 (165.1)	
		900/1500			9.25 (235.0)	6.75 (171.5)	
		2500			9.25 (235.0)	6.75 (171.5)	

Dimensions are for reference only and are subject to change.

How to Order

RTV1— O — PBW8 — RF8600 — TV8 — 316

Series	Inlet Type	Inlet Size	Outlet Type	Outlet Size	Flange Class	Packing Material	Vent Type and Size	Body Material	
RTV1	Needle O OS&Y	Fractional Tube Butt Weld Metric Tube Butt Weld Pipe Butt Weld	8 1/2 in. or 8 mm 12 3/4 in. or 12 mm 14 14 mm 16 1 in. or 16 mm 18 18 mm 20 1 1/4 in. or 20 mm 22 22 mm 24 1 1/2 in. 25 25mm 28 28mm	FNPT Female NPT NPT Male NPT FBT Female BSPT MBT Male BSPT FMS Female ISO MS Male ISO FBP Female BSPP RF RF Flange RTJ RTJ Flange	4 1/4 in. 6 3/8 in. 8 1/2 in. 12 3/4 in. 14 M1.4 x 1.5 16 1 in. 20 1 1/2 in. M20 x 1.5 22 M22 x 1.5 24 1 1/2 in. or M24 x 1.5 27 M27 x 2 32 2 in.	300 Class 300 600 Class 600 900 Class 900 1500 Class 1500 2500 Class 2500 4500 Class 4500	Graphite T PTFE	No Vent V4 1/4 Female NPT with Plug V8 1/2 Female NPT with Plug	316 316 S.S. 316L 316L S.S. 304 304 S.S. 304L 304L S.S. A105 A105 A400 Alloy 400 A20 Alloy 20 A600 Alloy 600 A825 Alloy 825 A276 Alloy C276 DU7 Duplex 2507