

Sampling Systems

Gas Samplers

Vapour Samplers

Liquid Samplers

Panel Mounted & Enclosed Samplers



Your **SMART** Partner
for **SMART** Products



Received **GOLD Award**
for **Made in India** Export Substitute
Product



Few of our **Approvals** and **Esteemed Customers**



General

HAVI Samplers are used to collect samples of Liquid or Gas from a Pipeline, Tank or a System. The Samples are collected in a Sampling Bomb and then transported for analysis in a Laboratory.

We offer a wide range of Sampling Systems suiting to the application requirement. All levels of sophistication are available right from Manual Sampling to Complex multi Sampling Bomb Systems. Toxic, flammable and corrosive medias are safely sampled using systems with all wetted parts in PTFE, PFA, Hastelloy and other exotic materials. Sampling systems are also available in 316L Stainless steel for less corrosive duties.

Traditional methods of sample taking have been rather crude and rudimentary. They have included open ended valves which have been allowed to flow into effluent drains to run clear any old product before flowing representative enough to take a sample. Or taking a first sample and discarding it before a second representative sample is taken. These traditional methods incur a lot of costs and can be environmentally unfriendly. Operator exposure is of great importance too and may require the use of expensive safety equipment and clothing. By using a representative sample the operator need only take the volume of sample required to carry out their tests, typically this can be only a few millilitres. Meaning far less spent sample media to dispose of saving additional costs.

Application

- To Validate Process Conditions of a System
- To ensure that the End Customer gets the Product meeting to the required Quality specifications
- To ensure Quality of End Product during Custody Transfer
- For online Monitoring of the System, Continuous flow Samplers are the best option.

ENGINEERED TO ORDER SAMPLERS

EASY TO USE AND MAINTAIN SYSTEMS

ENTIRE SYSTEM TESTED TO **FET** AS PER MESC CPECIFICATIONS

BEST FABRICATION WORKMANSHIP

Sampling System Selection

The basic Engineering of a Sampling System is to safely capture the sample from the Process line or a System. During this, it is very essential to ensure that the collected sample replicates the actual contents present in the Process. Variety of Sample's configuration are manufactured based on the type and criticality of the sample to be collected.

First important thing is to select the type of Container for the collected Sample. The Chart below will help you to identify the right Container for your Sample.

Sample type	Pressurised	Non Pressurised
Liquid	Container	Container / Bottle
Gas	Container	Container
Vapour	Container	Container

Range

Broadly classifying HAVI offers Sampling System for collection of Gases and Liquids. Depend on the application requirement, additional features such as Purge Line to clean the residual, Pressure Relief Valve, Continuous Flow are incorporated in the System. Sampling Systems are Engineered based on the Customer requirement and hence the below range is to cover the variety of options available with HAVI.

Series	Description
LLS	Sampling System for Liquid without Purging
LLSP	Sampling System for Liquid with Purging
GS	Sampling System for Gas / Vapour without Purging
GSP	Sampling System for Gas / Vapour with Purging
CLS	Online Sampling System for Liquid without Purging and Continuous Flow
CLSP	Online Sampling System for Liquid with Purging and Continuous Flow
CGS	Online Sampling System for Gas / Vapour without Purging and Continuous Flow
CGSP	Online Sampling System for Gas / Vapour with Purging and Continuous Flow

LLS Series

Liquid Sampler without Purge

This Sampling System are basic without Purge used for Liquid collection for general applications.

These are recommended for Fluids that are Non Toxic and does not have tendency to settle in the lines after sample is collected. These are also recommended for Fluid that returns to Flare line.

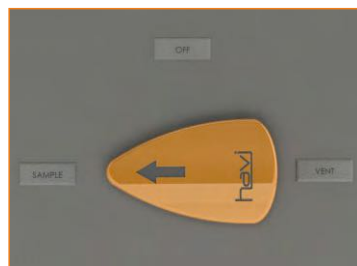

SAMPLE Mode

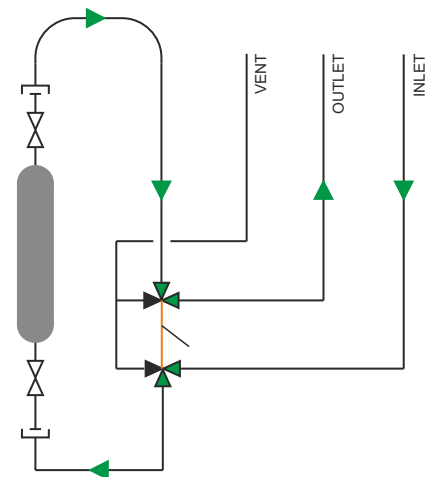

Process Fluid passes from Inlet through the Sampling Cylinder, Quick Connectors, Hose and other Fittings to the Outlet. The Fluid will flow as long as the Handle is in this Position.

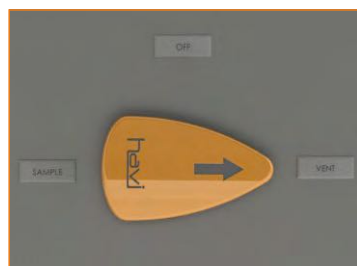

VENT Mode

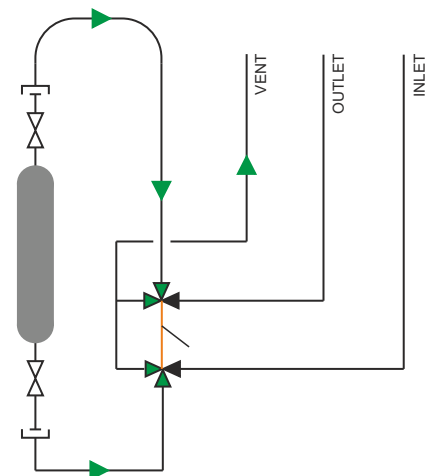

When the Sampling Cylinder is filled completely, the Tight Shut Valves on Cylinder are closed. Handle is turned to Vent position. Inlet and Outlet is Isolated and the fluid present in the line passes through Vent.

When handle is in OFF Position, Inlet, Outlet and Vent are stopped.

LLSP Series

Liquid Sampler with Purge

This Sampling System are basic with Purge used for Liquid collection for general applications. Purging can be done using a Gas or a Solvent to flush the Lines before or after the Sampling is done.

These are recommended for Fluids that are Non Toxic and have tendency to settle in the lines after sample is collected.

These are also recommended for Fluid that returns to Flare line.

FRONT VIEW



Process Fluid passes from Inlet through the Sampling Cylinder, Quick Connectors, Hose and other Fittings to the Outlet. The Fluid will flow as long as the Handle is in this Position.

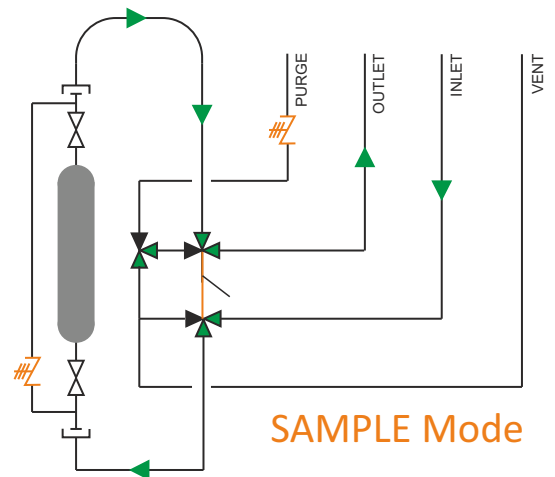

BACK VIEW



When the Sampling Cylinder is filled completely, the Tight Shut Valves on Cylinder are closed. Handle is turned to Vent position. Inlet and Outlet is Isolated and the fluid present in the line passes through Vent.

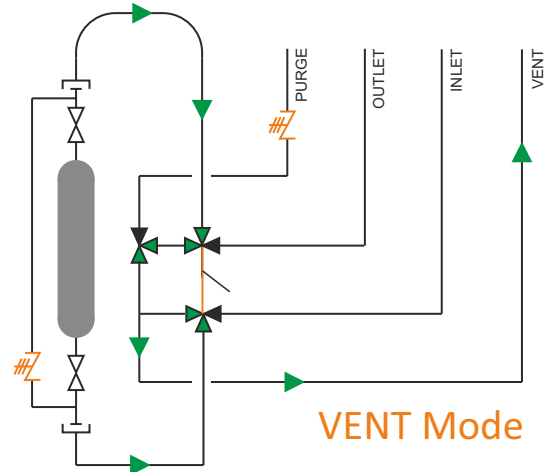

With the Vent Valve ON, Turn the Purge Valve to ON position. Purge will be activated to flush the filling lines from the opposite direction.

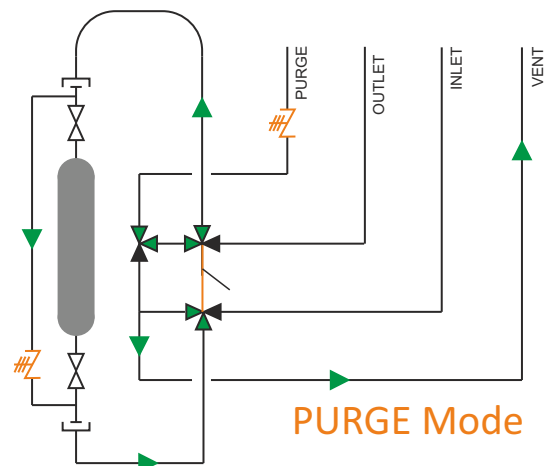

When handle is in OFF Position, Inlet, Outlet and Vent are stopped.

GS Series

Gas Sampler without Purge

This Sampling System are basic without Purge used for Gas collection for general applications.

These are recommended for Gases that are Non Toxic and does not have tendency to settle in the lines after sample is collected. These are also recommended for Fluid that returns to Flare line.

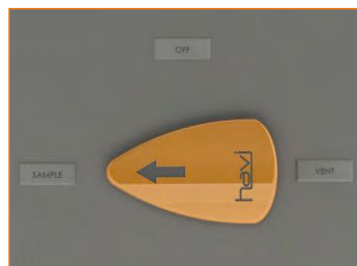

SAMPLE Mode

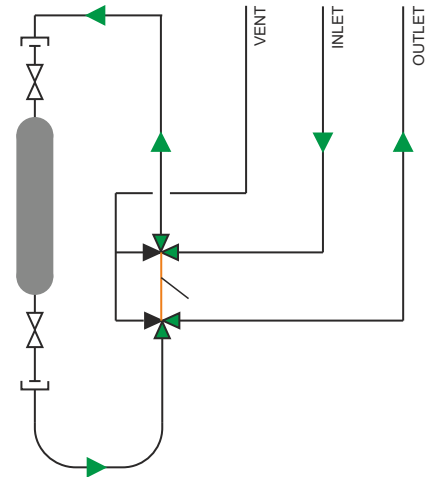

Process Fluid passes from Inlet through the Sampling Cylinder, Quick Connectors, Hose and other Fittings to the Outlet. The Fluid will flow as long as the Handle is in this Position.



VENT Mode

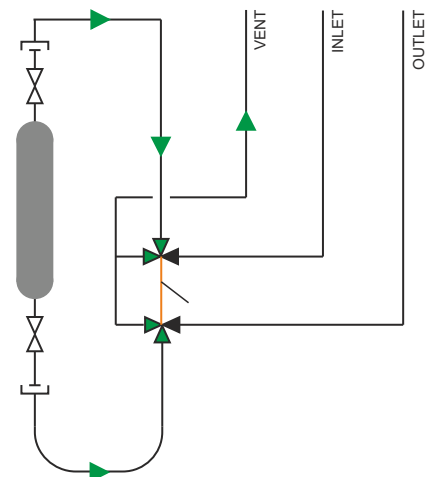

When the Sampling Cylinder is filled completely, the Tight Shut Valves on Cylinder are closed. Handle is turned to Vent position. Inlet and Outlet is Isolated and the fluid present in the line passes through Vent.

When handle is in OFF Position, Inlet, Outlet and Vent are stopped.

GSP Series

Gas Sampler with Purge

This Sampling System are basic with Purge used for Gas collection for general applications. Purging can be done using a Gas or a Solvent to flush the Lines before or after the Sampling is done.

These are recommended for Gases that are Non Toxic and have tendency to settle in the lines after sample is collected.

These are also recommended for Gas that returns to Flare line.



Process Fluid passes from Inlet through the Sampling Cylinder, Quick Connectors, Hose and other Fittings to the Outlet. The Fluid will flow as long as the Handle is in this Position.

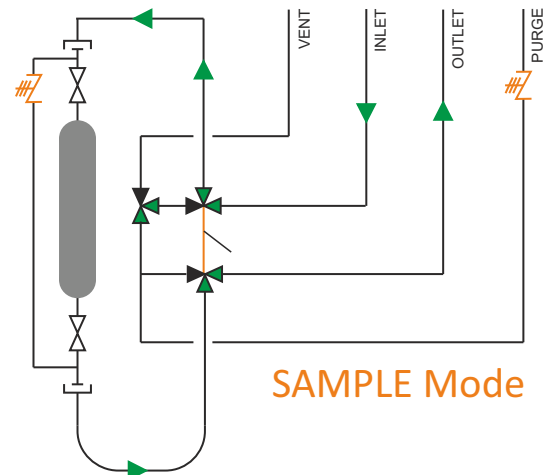

SAMPLE Mode



When the Sampling Cylinder is filled completely, the Tight Shut Valves on Cylinder are closed. Handle is turned to Vent position. Inlet and Outlet is Isolated and the fluid present in the line passes through Vent.

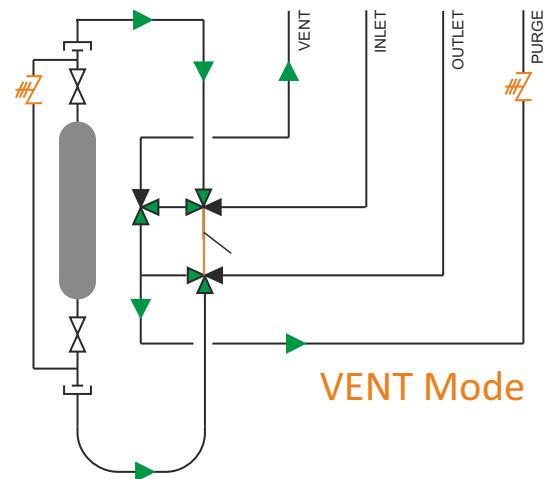

VENT Mode

With the Vent Valve ON, Turn the Purge Valve to ON position. Purge will be activated to flush the filling lines from the opposite direction.

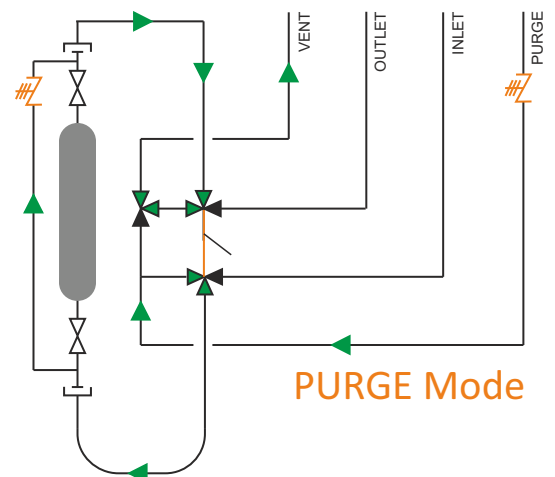

PURGE Mode

When handle is in OFF Position, Inlet, Outlet and Vent are stopped.

CLS Series

Continuous Flow Liquid Sampler without Purge

This Sampling System has the feature of Continuous Flow of Fluid from Inlet to Outlet during Vent and Off position. This System is without Purge and are used for Liquid collection for general applications.

These are recommended for Fluids that does not have tendency to settle in the lines after sample is collected. These are also recommended for Fluid that returns to Flare line.

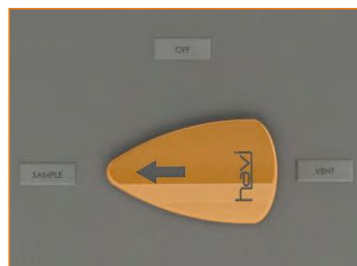

SAMPLE Mode

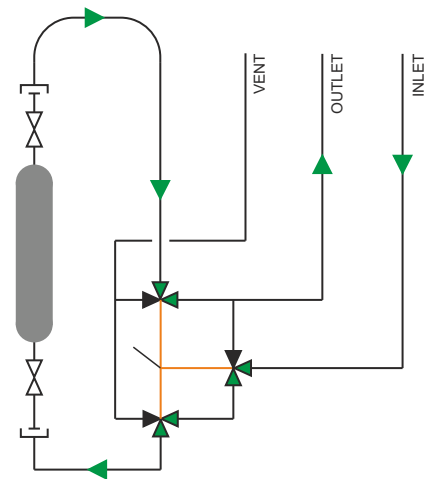

Process Fluid passes from Inlet through the Sampling Cylinder, Quick Connectors, Hose and other Fittings to the Outlet. The Fluid will flow as long as the Handle is in this Position.



VENT Mode

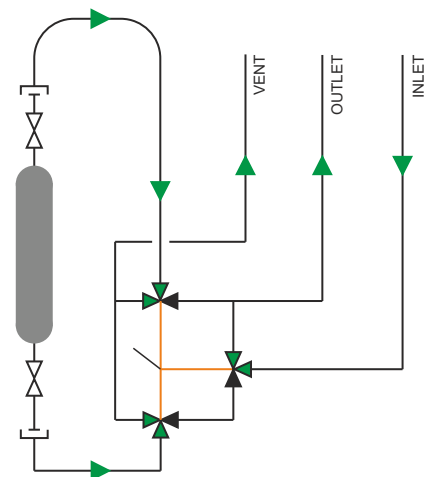

When the Sampling Cylinder is filled completely, the Tight Shut Valves on Cylinder are closed. Handle is turned to Vent position. Inlet and Outlet will flow continuously and the fluid present in the line passes through Vent.

When handle is in OFF Position, Inlet & Outlet Flow is not halted.

CLSP Series

Continuous Flow Liquid Sampler with Purge

This Sampling System has the feature of Continuous Flow of Fluid from Inlet to Outlet during Vent and Off position. This System is with Purge and are used for Liquid collection for general applications.

These are recommended for Fluids that have tendency to settle in the lines after sample is collected. These are also recommended for Fluid that returns to Flare line.

FRONT VIEW



Process Fluid passes from Inlet through the Sampling Cylinder, Quick Connectors, Hose and other Fittings to the Outlet. The Fluid will flow as long as the Handle is in this Position.

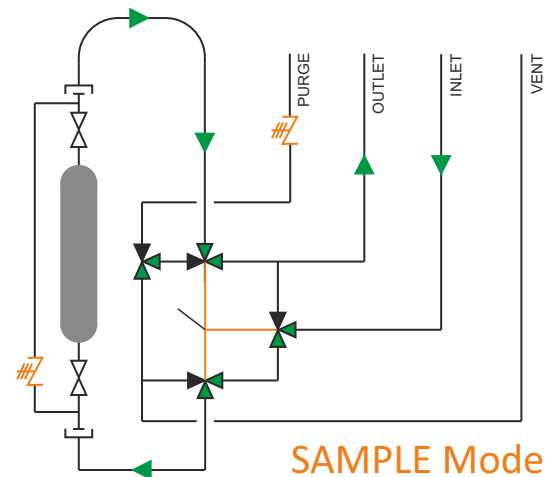

When the Sampling Cylinder is filled completely, the Tight Shut Valves on Cylinder are closed. Handle is turned to Vent position. Inlet and Outlet will flow continuously and the fluid present in the line passes through Vent.

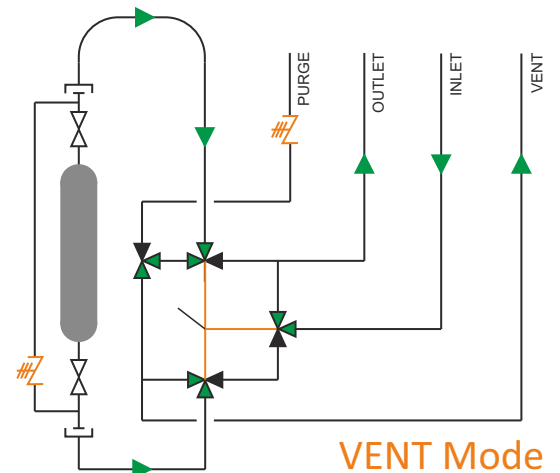

With the Vent Valve ON, Turn the Purge Valve to ON position. Purge will be activated to flush the filling lines from the opposite direction.

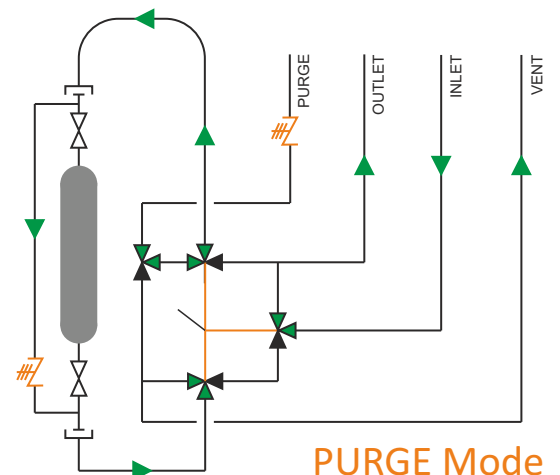

When handle is in OFF Position, Inlet & Outlet Flow is not halted.

BACK VIEW



CGS Series

Continuous Flow Gas Sampler without Purge

This Sampling System has the feature of Continuous Flow of Gas from Inlet to Outlet during Vent and Off position. This System is without Purge and are used for Liquid collection for general applications.

These are recommended for Gases that does not have tendency to settle in the lines after sample is collected. These are also recommended for Fluid that returns to Flare line.

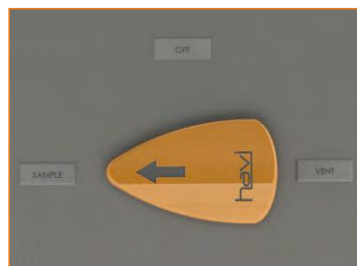

SAMPLE Mode

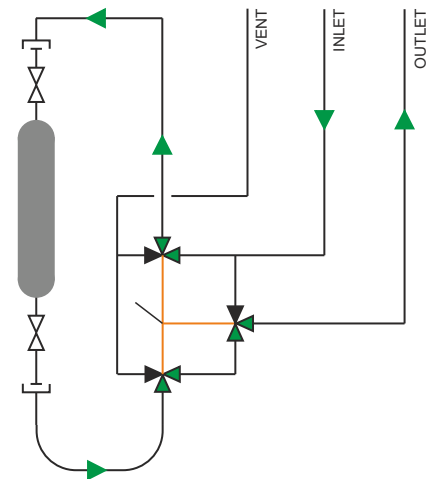

Process Fluid passes from Inlet through the Sampling Cylinder, Quick Connectors, Hose and other Fittings to the Outlet. The Fluid will flow as long as the Handle is in this Position.

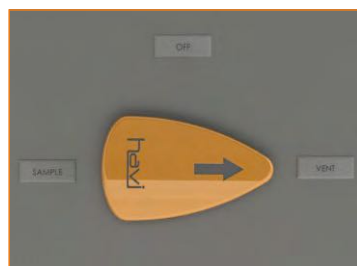

VENT Mode

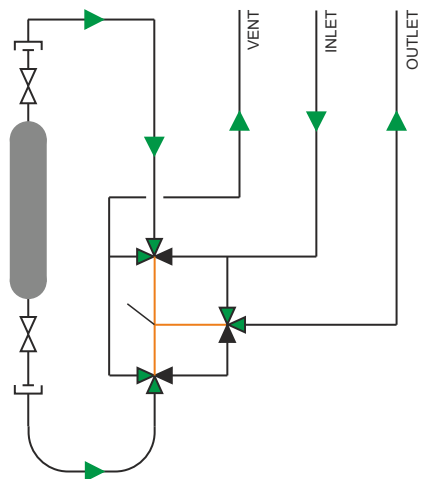

When the Sampling Cylinder is filled completely, the Tight Shut Valves on Cylinder are closed. Handle is turned to Vent position. Inlet and Outlet will flow continuously and the fluid present in the line passes through Vent.

When handle is in OFF Position, Inlet & Outlet Flow is not halted.

CGSP Series

Continuous Flow Gas Sampler with Purge

This Sampling System has the feature of Continuous Flow of Fluid from Inlet to Outlet during Vent and Off position. This System is with Purge and are used for Liquid collection for general applications.

These are recommended for Fluids that have tendency to settle in the lines after sample is collected. These are also recommended for Fluid that returns to Flare line.



FRONT VIEW

Process Fluid passes from Inlet through the Sampling Cylinder, Quick Connectors, Hose and other Fittings to the Outlet. The Fluid will flow as long as the Handle is in this Position.

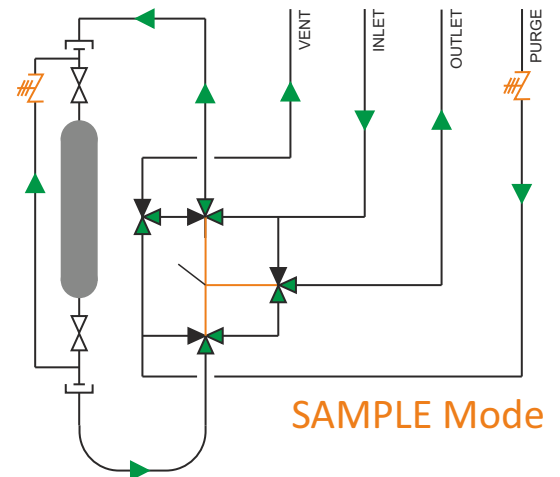

BACK VIEW

When the Sampling Cylinder is filled completely, the Tight Shut Valves on Cylinder are closed. Handle is turned to Vent position. Inlet and Outlet will flow continuously and the fluid present in the line passes through Vent.

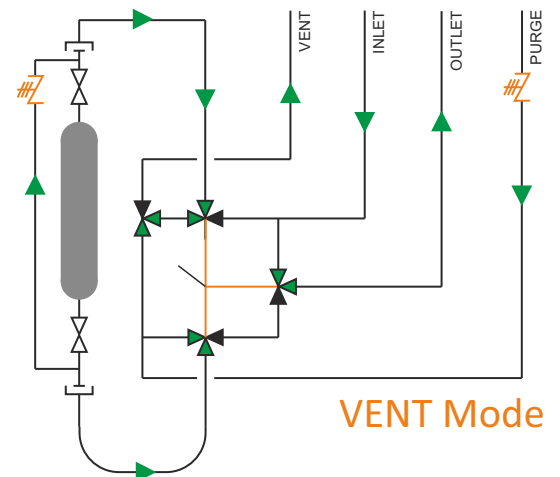

With the Vent Valve ON, Turn the Purge Valve to ON position. Purge will be activated to flush the filling lines from the opposite direction.

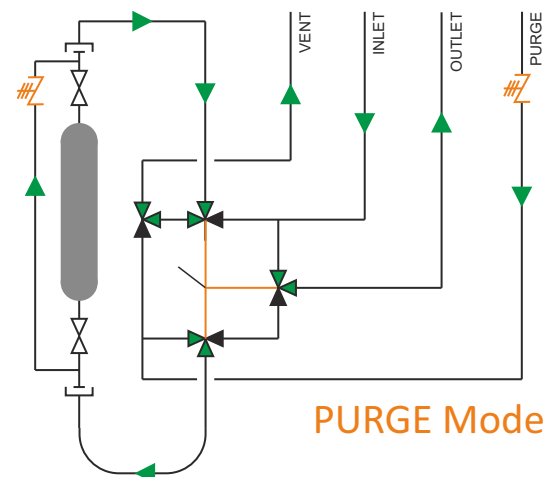

When handle is in OFF Position, Inlet & Outlet Flow is not halted.

General

Sampling Cylinders comes in various sizes based on the volume of the Sample to be collected. Material selection of Cylinders depends on the type of Sample. HAVI manufactures various sizes of Sampling Cylinder with different configurations.



- Available with or without Purging Tube
- Option of Handle on the Cylinder
- Choice of Quick Connectors type
- Comes with Tight Shut Needle Valves
- Option of Outage Tube to provide Vapour space
- Inlet & Outlet size of 1/4" and 1/2"

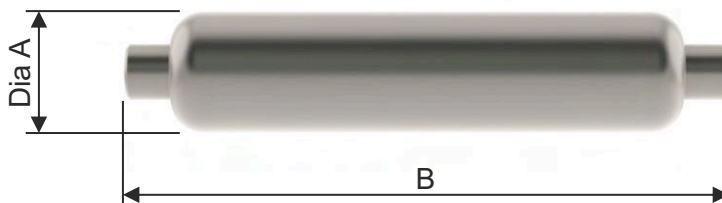

Volume	A	B
150 ML	140	2" Pipe
300 ML	300	2" Pipe
400 ML	350	2" Pipe
500 ML	410	2" Pipe
1000 ML	340	3" Pipe

Note: Custom size of Cylinders based on the Volume can also be Designed and manufactured



Prefabricated
Hook-ups

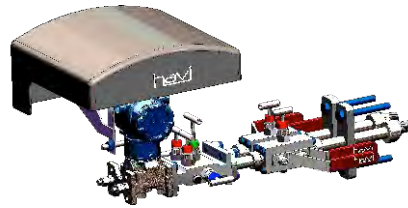

Closed-couple
DBB Hook-up

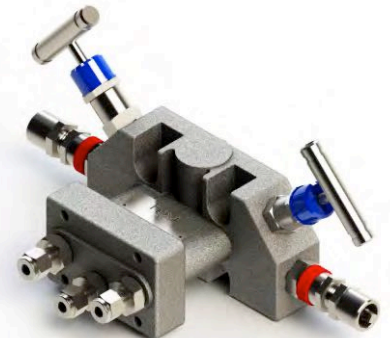

Modular
Manifolds



Monoflange
Valves



Manifold
Valves



Tube & Pipe
Fittings

For more
Technical
Information
Call on

+91 91450 89528

Specify the Product you want information on



Plant

Gat No. 379, Nighoje,
Chakan MIDC, Vasti-Khud,
Pune 410501,
Maharashtra, INDIA.



HAVI ENGINEERING INDIA PVT LTD

Office

A-201, Prime Trade Center, Sativali Road, Vasai East
Palghar 401208, Maharashtra, INDIA

sales@havi.in
www.havi.in

Компания ВСП

107023, Россия, Москва,
Семеновская площадь, 1а, 18 этаж
+7 499 4040080

vsp@vsp-co.org
www.vsp-co.org