

SR NO	DESCRIPTION	QTY	MATERIAL
1	BODY	1	SS 316
2	NUT	1	SS 316
3	FRONT FERRULE	1	SS 316
4	BACK FERRULE	1	SS 316

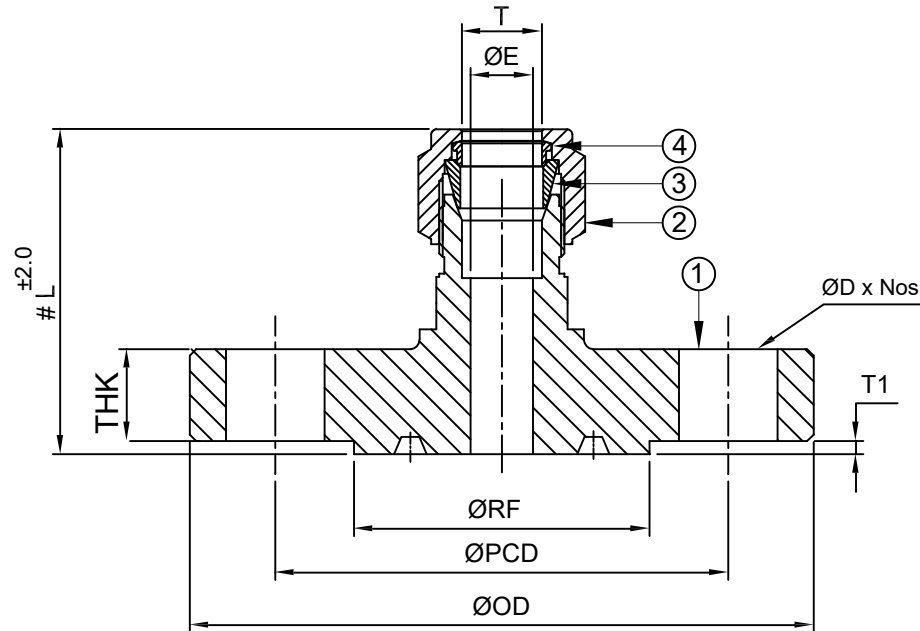

SR NO	PART NO	FLANGE SIZE	FLANGE RATING	ØOD	ØPCD	ØRF	T1	THK	ØD X Nos	T	ØE	L
1	12MFLARTDN15PN100	DN 15	PN 100	105	75	55	2	18	Ø14 X 4 Nos	12mm	10.3	53.0

PART NAME : FLANGE ADAPTOR - TUBE OD x FLANGE RTJ				CUSTOMER NAME:-			
DWG NO : 12MFLARTDN15PN100-S6				PROJECT NAME:-			
MATERIAL : SS 316				End User Name:-			
DRAWN BY : VK				SIGN : _____			
CHECKED BY : RW				DATE : 09.09.2022			
APPROVED BY : SB				DATE : 09.09.2022			
REV NO		DESCRIPTION		SIGN		DATE	
ENQ NO: EN2223/00609		SHEET NO: 01 OF 01		SO NO: -		End User Name:-	
* All dimensions are in mm. Dimensions for reference only and are subject to change without notice		* This document is the property of Havi Engineering India Pvt. Ltd. No exploitation or release of any text contained herein or relating to this document is permitted in any form without the written consent of HAVI.		REV NO: 00		SCALE: NTS	

NOTE:  
• # MARKED DIMENSION IS IN FINGER TIGHT POSITION.



PATH:-T:\2022-2023\EXPORT\EN22300609