

SR NO	QTY
20	05

SR NO	DESCRIPTION	QTY	MATERIAL
1	BODY	1	SS 316
2	NUT	1	SS 316
3	FRONT FERRULE	1	SS 316
4	BACK FERRULE	1	SS 316

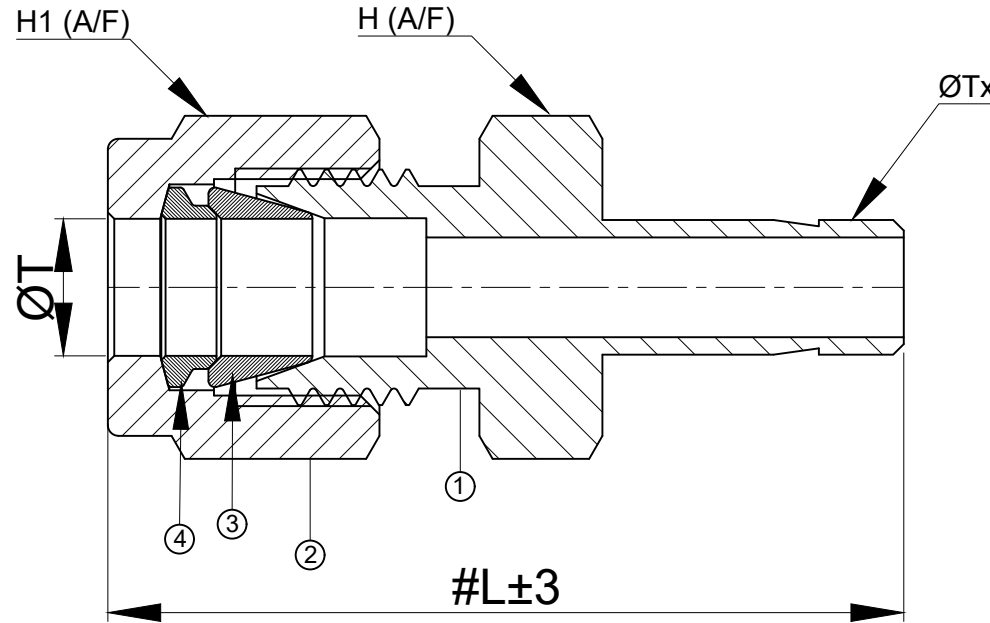

PART NO	ØT	ØTx	L	H (A/F)	H1 (A/F)
2R4-S6	1/8"	1/4"	43.0	11(7/16")	11(7/16")

 info@havi.in www.havi.in A-201, PRIME TRADE CENTER SATIVALI ROAD, VASAI (E), PALGHAR - 401208, MAHARASHTRA, INDIA	PART NAME : REDUCER 1/8" ODT x 1/4" ODT STUB				END USER:-	
	DWG NO : - 2R4-S6				CLIENT NAME:-	
	MATERIAL : - 6MO				PROJECT NAME:-	
					ENQ NO:-	
				SO NO:-		 SHEET NO: 01 OF 01
SIGN		DATE		SIGN		
DRAWN BY		SB		18.12.2021		* All dimensions are in mm. Dimensions for reference only and are subject to change without notice * This document is the property of Havi Engineering India Pvt. Ltd. No exploitation or release of any text contained herein or relating to this document is permitted in any form without the written consent of HAVI.
CHECKED BY		RW		18.12.2021		
APPROVED BY		SM		18.12.2021		
						REV NO: 00
						SCALE: NTS

NOTE:
 • # MARKED DIMENSION IS IN FINGER TIGHT POSITION.

PATH: J:\2023-2024\EXPORT\EN232400023\EN232400023R0