

FRONT FERRULE

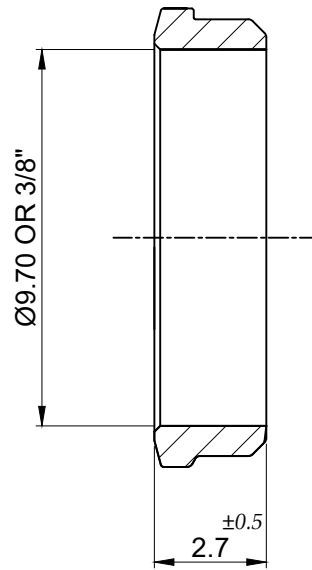

BACK FERRULE

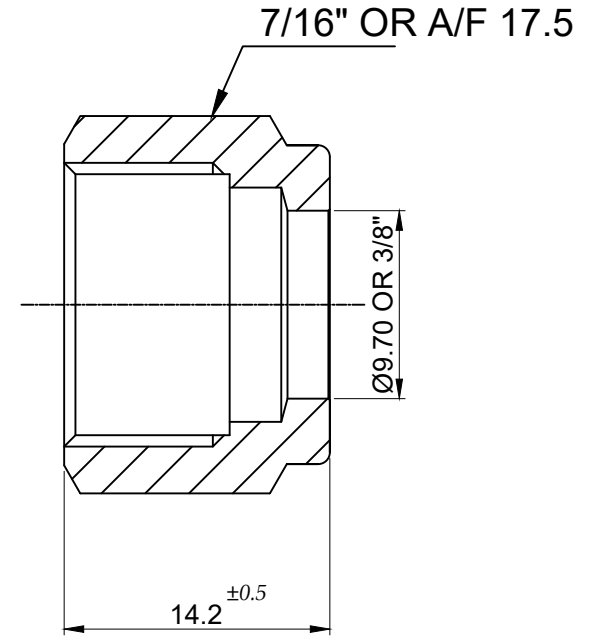

NUT

- NOTE:
- # MARKED DIMENSION IS IN FINGER TIGHT POSITION.
 - NPT THREAD AS PER ANSI B 1.20.1.

	SIGN	DATE
DRAWN BY	PG	27-03-2023
CHECKED BY	MC	27-03-2023
APPROVED BY	SRD	27-03-2023



www.havi.in
info@havi.in

PART NAME : 3/8" Back Ferrule, Front Ferrule & Nut				CUSTOMER NAME:-	
DWG NO : 6BFFFN-S6				PROJECT NAME:-	
MATERIAL : SS 316				PO NO:-	
				ENQ NO: EN2223/01092	
				SO NO: -	
REV NO	DESCRIPTION	SIGN	DATE		
<p>* All dimensions are in mm. Dimensions for reference only and are subject to change without notice * This document is the property of Havi Engineering India Pvt. Ltd. No exploitation or release of any text contained herein or relating to this document is permitted in any form without the written consent of HAVI.</p>					
				REV NO: 00	SHEET NO: 01 OF 01
				SCALE: NTS	