

146(APPROX)

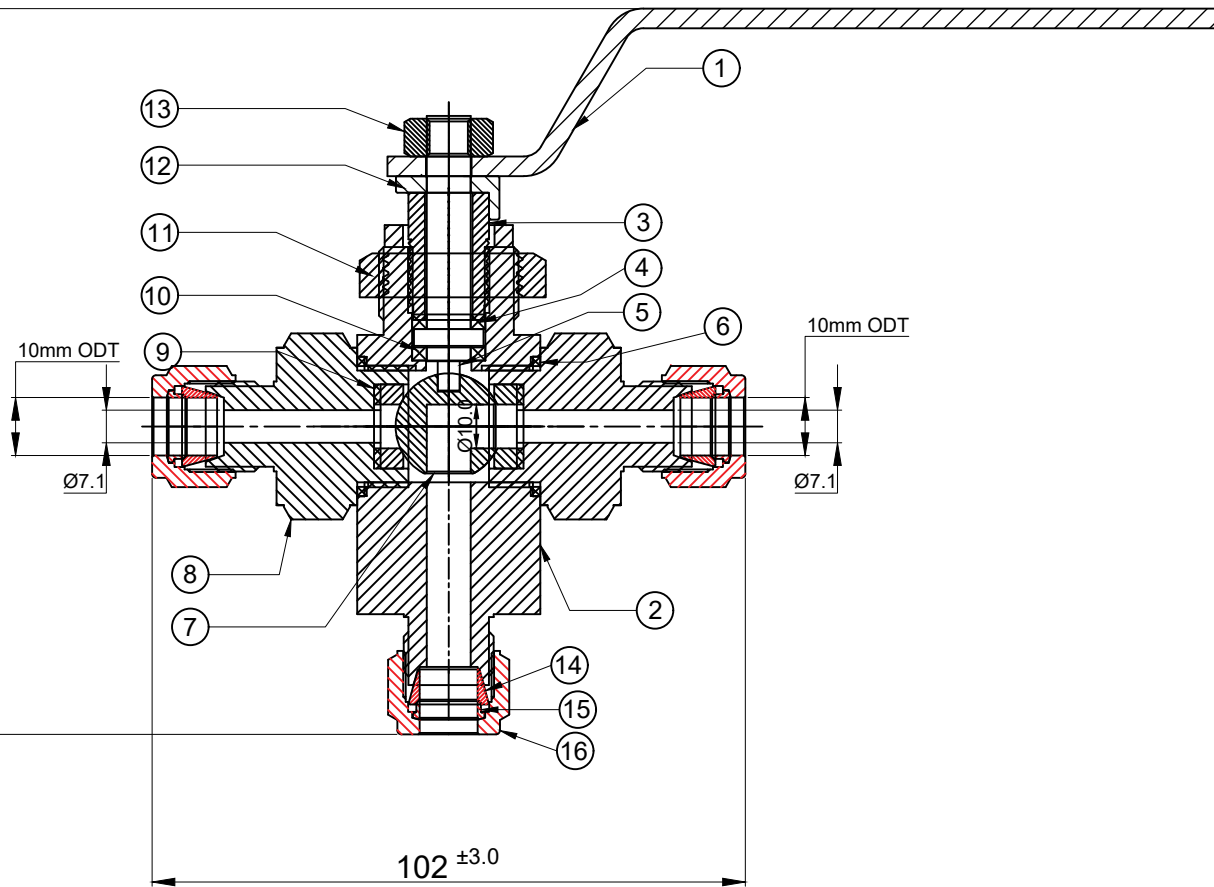

SR.	DESCRIPTION	MATERIAL	QTY
1	Handle	SS 304	1
2	Body	ASTM A479 Gr.316	1
3	Pusher	ASTM A479 Gr.316	1
4	Packing	PTFE	1
5	Spindle	ASTM A479 Gr.316	1
6	Seal Ring	PTFE	2
7	Ball	ASTM A479 Gr.316	1
8	End Connector	ASTM A479 Gr.316	2
9	Seat	PEEK	2
10	Thrust Washer	PTFE	1
11	Panel Nut	ASTM A479 Gr.316	1
12	Locker	ASTM A479 Gr.316	1
13	Handle Nut	ASTM A479 Gr.316	1
14	Front Ferrule	ASTM A479 Gr.316	3
15	Back Ferrule	ASTM A479 Gr.316	3
16	Nut	ASTM A479 Gr.316	3

DATA SHEET

Type : 3 Way 'L' Port
 Connection : 10mm ODT

Working Press : 6000 psi
 Seat Test (Hydro) : 6600 psi
 Body Test (Hydro) : 9000 psi
 Pneumatic Seat Test : 90 psi



PART NAME : Medium Pressure Ball Valve 3 way, 10mm ODT				CUSTOMER NAME : VSP			
DWG NO : - MLBV-10B-10MT3W-S6				PROJECT NAME & NO:			
MATERIAL : - SS316L				EN NO: EN2324/00653		SHEET NO: 01 OF 01	
SIGN		DATE		SIGN		DATE	
DRAWN BY: BKR		12-03-2024		SO NO: SO2324/00357		REV NO: 00	
CHECKED BY: PDG		12-03-2024		* All dimensions are in mm. Dimensions for reference only and are subject to change without notice			
APPROVED BY: SRD		12-03-2024		* This document is the property of Havi Engineering India Pvt. Ltd. No exploitation or release of any text contained herein or relating to this document is permitted in any form without the written consent of HAVI.			
				SCALE: NTS			