

SR NO	DESCRIPTION	MATERIAL	QTY
1	BODY	ASTM A182 Gr.SS316	1
2	NUT	ASTM A479 Gr.SS316	2
3	FRONT FERRULE	ASTM A479 Gr.SS316	2
4	BACK FERRULE	ASTM A479 Gr.SS316	2
5	TIP	ASTM A479 Gr.SS316	1
6	BONNET PACKING	ASTM A479 Gr.SS316	1
7	GLAND PACKING	GFT	1
8	GLAND WASHER	ASTM A479 Gr.SS316	1
9	BONNET PUSHER	ASTM A479 Gr.SS316	1
10	HANDLE	SS316	1
11	GRUB SCREW	SS304	2
12	SPINDLE	ASTM A479 Gr.SS316	1
13	DRAIN CAP	ALUMINIUM	1
14	CHECK NUT	SS304	1
15	BONNET	ASTM A479 Gr.SS316	1
16	DOWEL PIN	SS304	1

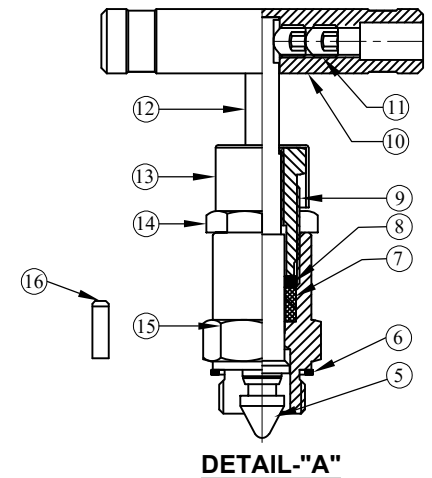

SR No.	PART NAME	PROCESS CONN.	INSTRUMENT CONN.	#L
01	NVBS-6MT-6MT-S6-N	6mm ODT	6mm ODT	63.0

Technical Data:-

- M.W.T.: -54° C To +260° C
- MWP.: 6000 psig @ 100 °F
- ORIFICE-Ø4mm
- NACE MR 0175 Applicable
- Seat Test Press (Hydro): 6600 psig
- Seat Test Press (Pneu): 90 psig
- Body Test Press (Hydro): 9000 psig

	SIGN	DATE
DRAWN BY	MBC	16.08.2023
CHECKED BY	VM	16.08.2023
APPROVED BY	SRD	16.08.2023



PART NAME : BAR STOCK NEEDLE VALVE ODT X ODT		CUSTOMER NAME:	
DWG NO : NVBS-6MT-6MT-S6-N		END USER NAME: -	
MATERIAL : AS PER BOM		P.O. No.:- VSP-14041798	
REV NO		DESCRIPTION	
SIGN		DATE	
SO NO:- SO2324/00163		ENQ No.: EN2223/01008	
* All dimensions are in mm. Dimensions for reference only and are subject to change without notice		SHEET NO: 01 OF 01	
* This document is the property of Havi Engineering India Pvt. Ltd. No exploitation or release of any text contained herein or relating to this document is permitted in any form without the written consent of HAVI.		REV NO: 00	
		SCALE: NTS	