

SR.No	DESCRIPTION	MATERIAL	QTY
1	ADAPTOR	ASTM A479 Gr. SS316	1
2	NUT	ASTM A479 Gr. SS316	1
3	SEAL RING	PTFE	1
4	CONNECTOR	ASTM A479 Gr. SS316	1

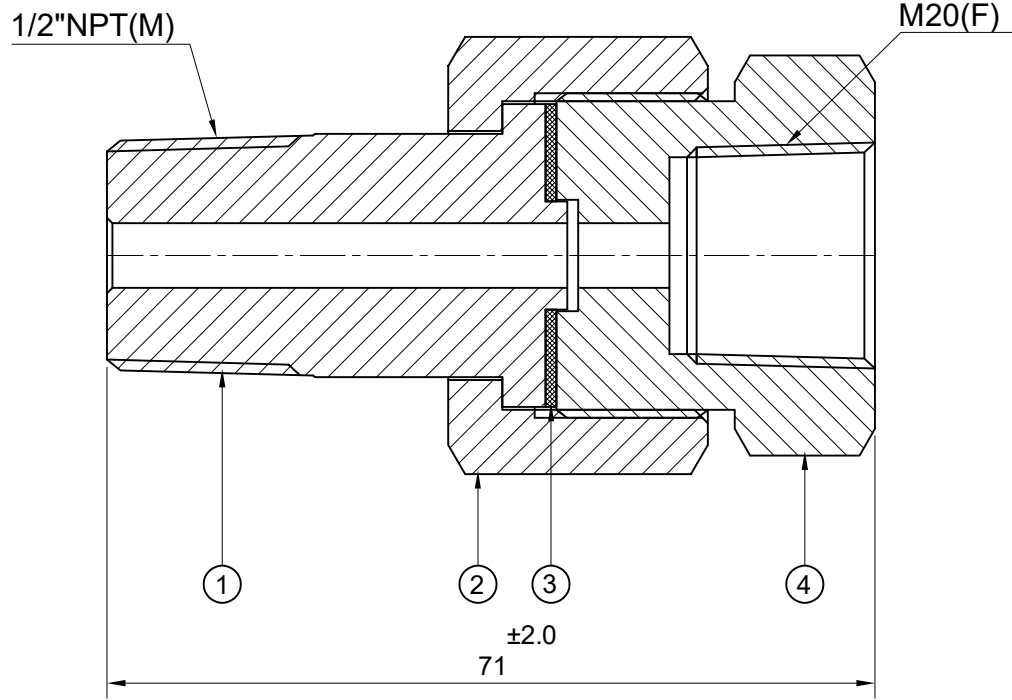

**havi**  
**Fittings & Valves**  
 info@havi.in www.havi.in  
 A-201, PRIME TRADE CENTER  
 SATIVALI ROAD, VASAI (E),  
 PALGHAR - 401208, MAHARASHTRA, INDIA

	SIGN	DATE
DRAWN BY	VK	01.07.2022
CHECKED BY	RW	01.07.2022
APPROVED BY	SM	01.07.2022

PART NAME : Swivel Guage Adatpor 1/2" NPT-M X M20-F

CUSTOMER NAME:  
-

DWG NO : - SGA-8M-M20F-S6  
 MATERIAL :- AS PER BOM

PROJECT NAME & NO:  
-

ENQ NO: EN2223/00286

SO NO:

SHEET NO:  
01 OF 01

\* All dimensions are in mm. Dimensions for reference only and are subject to change without notice  
 \* This document is the property of Havi Engineering India Pvt. Ltd. No exploitation or release of any text contained herein or relating to this document is permitted in any form without the written consent of HAVI.

REV NO: 00  
 SCALE: NTS