

Sr No.	Description	Material	Qty
1	Tip	ASTM A479 Gr.SS316	2
2	Bonnet Packing	ASTM A479 Gr.SS316	2
3	Gland Packing	GRAPHITE	2 Set
4	Gland Washer	ASTM A479 Gr.SS316	2
5	Bonnet Pusher	ASTM A479 Gr.SS316	2
6	Handle	SS 304	2
7	Grub Screw	SS 304	4
8	Spindle	ASTM A479 Gr.SS316	2
9	Drain Cap	ALUMINIUM	2
10	Check Nut	SS316	2
11	Bonnet	ASTM A479 Gr.SS316	2
12	Dowel Pin	SS304	2
13	Body	ASTM A182 Gr.F316	1
14	Drain Plug	ASTM A479 Gr.SS316	1

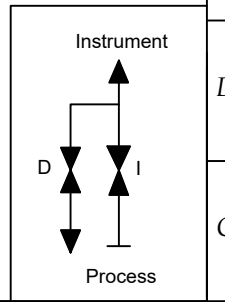
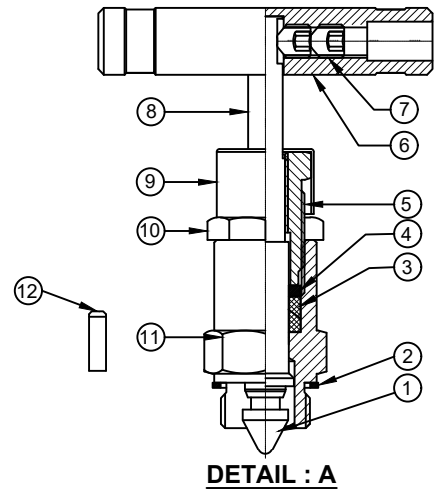

**TECHNICAL DETAILS:**

- Process Side: 1/2" NPT-F
- Instrument Side: 1/2" NPT-F
- Drain: 1/4" NPT-F (Plugged)
- Screwed Bonnet Design
- MWP : 6000 psig @100°F
- Seat Test Press (Hydro): 6600 psig
- Seat Test Press (Pneu): 90 psig
- Body Test Press (Hydro) : 9000 psig

**havi**  
Fittings & Valves  
info@havi.in www.havi.in  
A-201, PRIME TRADE CENTER  
SATIVALI ROAD, VASAI (E),  
PALGHAR - 401208, MAHARASHTRA, INDIA

	SIGN	DATE
DRAWN BY	MCB	04.07.2023
CHECKED BY	VM	04.07.2023
APPROVED BY	SRD	04.07.2023

PART NAME : 2 Valve Manifold Remote Mounting 1/2"NPT-F x 1/2"NPT-F x 1/4" NPTF DRAIN		CUSTOMER NAME :	
DWG NO : - SV2E-8F-8F-S6-G		PROJECT NAME :	
MATERIAL : - AS PER BOM		ENQ NO: EN2324/00354	
REV NO	DESCRIPTION	SIGN	DATE
* All dimensions are in mm. Dimensions for reference only and are subject to change without notice		SO NO:	
* This document is the property of Havi Engineering India Pvt. Ltd. No exploitation or release of any text contained herein or relating to this document is permitted in any form without the written consent of HAVI.		SHEET NO: 01 OF 01	
		REV NO: 00	
		SCALE: NTS	

PATH: \\W:\2023-2024\EXPORT\EN232400354\GAD