

Sr No.	Description	Material	Qty
1	Tip	ASTM A479 Gr.SS316	2
2	Bonnet Packing	ASTM A479 Gr.SS316	2
3	Gland Packing	GFT	2 Set
4	Gland Washer	ASTM A479 Gr.SS316	2
5	Bonnet Pusher	ASTM A479 Gr.SS316	2
6	Handle	SS 304	2
7	Grub Screw	SS 304	4
8	Spindle	ASTM A479 Gr.SS316	2
9	Dust Cap	ALUMINIUM	2
10	Check Nut	SS304	2
11	Bonnet	ASTM A479 Gr.SS316	2
12	Dowel Pin	SS304	2
13	Body	ASTM A182 Gr.F316	1
14	Drain Plug	ASTM A479 Gr.SS316	1

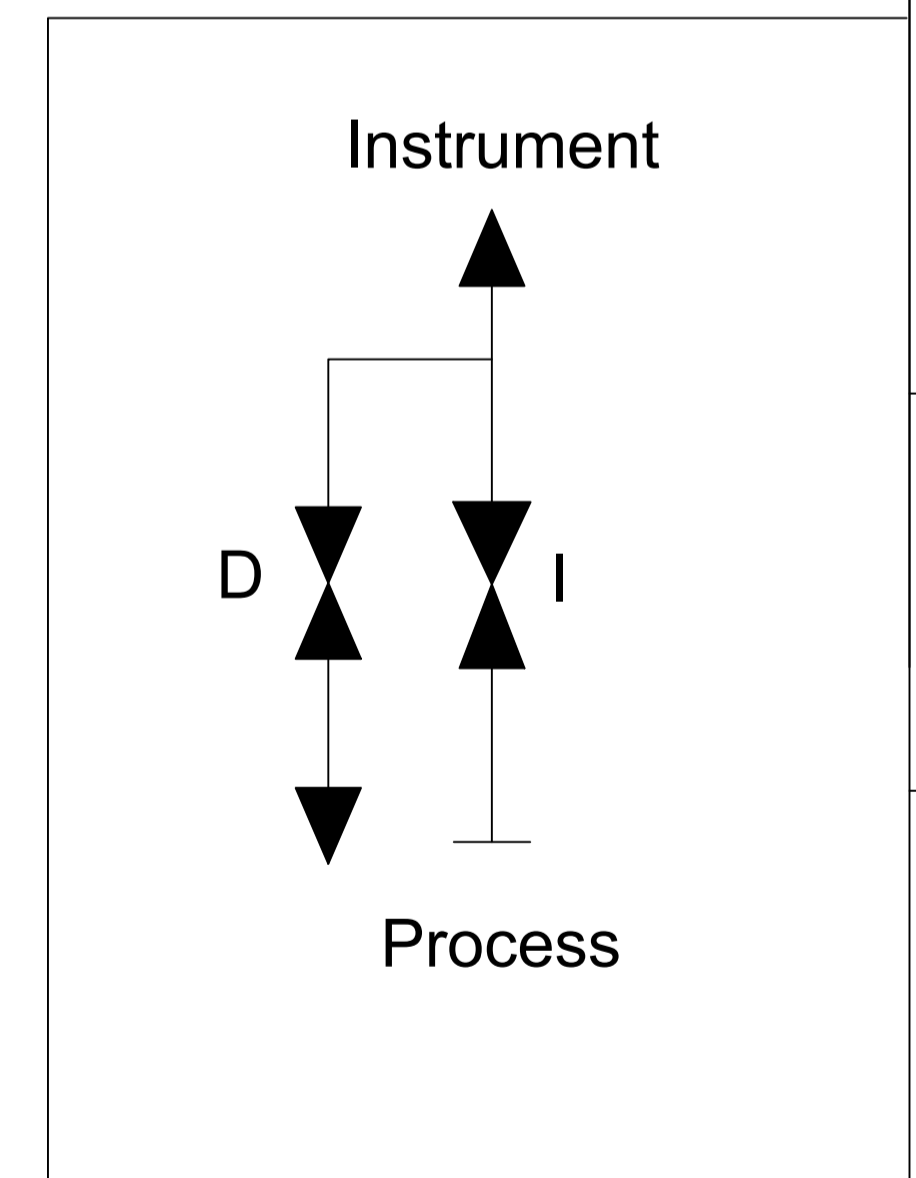
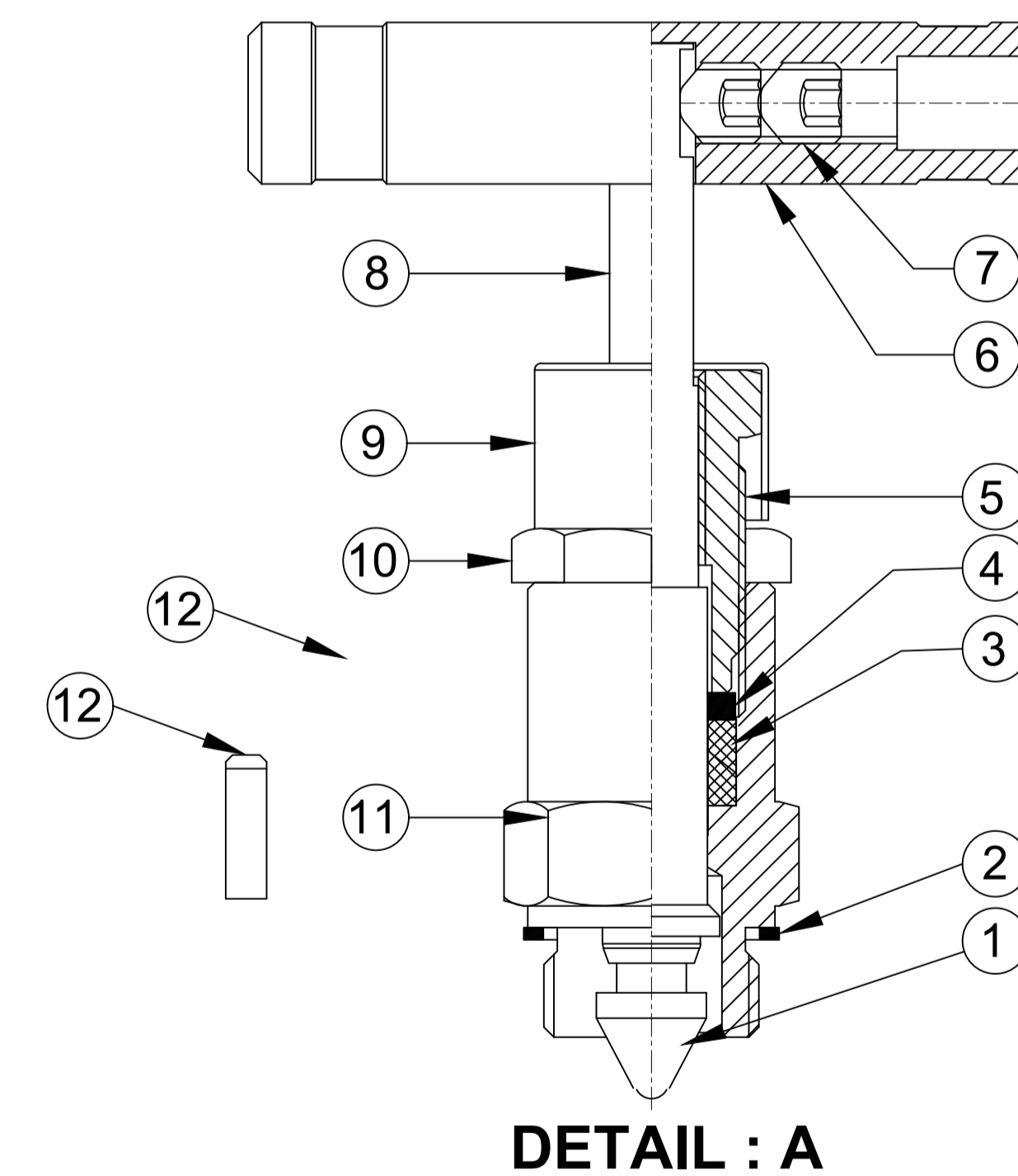

TECHNICAL DETAILS:

- Process Side: 1/2" NPT-M
- Instrument Side: 1/2" NPT-F
- Drain: 1/4" NPT-F (Plugged)
- Screwed Bonnet Design
- MWT.: -54°C To +260°C
- MWP.: 6000 psig @ 100 °F
- Body Test Press (Hydro): 9000 psig
- Seat Test Press (Hydro): 6600 psig
- Seat Test Press (Pneu): 90 psig

<p>havi Fittings & Valves info@havi.in www.havi.in A-201, PRIME TRADE CENTER SATIVALI ROAD, VASAI (E), PALGHAR - 401208, MAHARASHTRA, INDIA</p>	PART NAME : 2 Valve Remote Mounted Manifold Valve -Type E, 1/2"NPTM x 1/2"NPTF X 1/4" NPTF DRAIN		CUSTOMER NAME:					
	DWG NO : - SV2E-8M-8F-S6		PROJECT NAME & NO:					
	MATERIAL : - AS PER BOM		ENQ NO:-					
			SO NO: SO2324/00304					
	SIGN	DATE	REV NO	DESCRIPTION	SIGN	DATE	SO NO: SO2324/00304	SHEET NO: 01 OF 01
DRAWN BY	BKR	23.11.2023		* All dimensions are in mm. Dimensions for reference only and are subject to change without notice				REV NO: 00
CHECKED BY	PDG	23.11.2023		* This document is the property of Havi Engineering India Pvt. Ltd. No exploitation or release of any text contained herein or relating to this document is permitted in any form without the written consent of HAVI.				SCALE: NTS
APPROVED BY	SRD	23.11.2023						