

# IR5000 Series

## Single-Stage, High Sensitivity Pressure Regulator

Internal Threadless • Stainless Steel



### Value Proposition:

When precise outlet pressure control is a must, Parker's IR5000 Series is the solution. The single-stage, high-sensitivity regulator handles pressures up to 3,500 psig. Corrosion resistance is no problem with its large, convoluted Hastelloy® C-22 diaphragm. Close tolerances and tight alignment of moving components minimize hysteresis and improve cycle life.

### Product Features:

- Unique compression member loads the seal to the body without requiring a threaded nozzle or additional seals
- Internally threadless design reduces particle generation; low internal volume reduces purge times
- Positive upward and downward stops increase cycle life by preventing over stroking of the diaphragm
- Selection of seat materials for media compatibility and temperature applications

### Specifications:

Functional Performance	
<b>Design</b>	
Burst Pressure	10,500 psig (724 barg)
Proof Pressure	5,250 psig (362 barg)
<b>Flow Capacity</b>	
C <sub>v</sub> Options	C <sub>v</sub> 0.06 (std), C <sub>v</sub> 0.02, C <sub>v</sub> 0.15
<b>Leak Rate: Internal</b>	Bubble Tight
<b>Leak Rate: External</b>	Bubble Tight
<b>Supply Pressure Effect</b>	Based upon C <sub>v</sub> Option
0.02 C <sub>v</sub>	0.12 psig/100 psig (0.008 barg/7 barg)
0.06 C <sub>v</sub>	0.3 psig/100 psig (0.02 barg/7 barg)
0.15 C <sub>v</sub>	0.75 psig/100 psig (0.05 barg/7 barg)
<b>Internal Volume</b>	19.5 cc without fittings
<b>Approximate Weight</b>	4.5 lbs. (2.1 kg)
Operating Conditions	
Maximum Inlet	Refer to Range Table for specific information
Outlet Options	0 - 5 psig (.3 barg), 1-30 psig (2 barg) 2 - 60 psig (4 barg), 3-100 psig (7 barg) 0-250 psig (17 barg)
<b>Temperature (Standard)</b>	Metal Knob required for temperature above 150°F
PCTFE	-40°F to 150°F (-40°C to 66°C)
PEEK™	-40°F to 272°F (-40°C to 135°C)
Vespel®	-40°F to 500°F (-40°C to 260°C)
Low Pressure IR5000 (P)	-40°F to 150°F (-40°C to 66°C)

Material of Construction	
Wetted	
Body Options	316L Stainless Steel
Compression Member	Inconel® 625
Diaphragm	Hastelloy® C-22
Poppet	Hastelloy® C-22
Poppet Spring	Inconel® X750
Seat Options	PCTFE (std) Vespel® or PEEK™
Carrier Options	316L Stainless Steel (std) or Hastelloy® C-22
Washer Backup Options	316L Stainless Steel (std) or Hastelloy® C-22
O-Ring Backup Options	FKM (std) or PTFE
Inlet Screen/Filter	316 Stainless Steel (std) (60µm mesh screen, 10µm filter)
Non-Wetted	
Cap Options	Nickel Plated Brass or Stainless Steel
Nut	Stainless Steel
Knob Options	ABS (std) (ambient temperature) or Aluminum

For additional information on materials of construction, functional performance and operating conditions, please contact factory.

Hastelloy® C-22 and Hastelloy C-276® are registered trademarks of Haynes International, Inc. PEEK™ is a trademark of Victrex plc. Inconel® and Monel® are registered trademarks of Special Metals Corporation. Vespel® is a registered trademark of DuPont Performance Elastomers L.L.C.



INSTRUMENTATION PRODUCTS DIVISION

ENGINEERING YOUR SUCCESS.

# IR5000 Series

## Flow Curve:

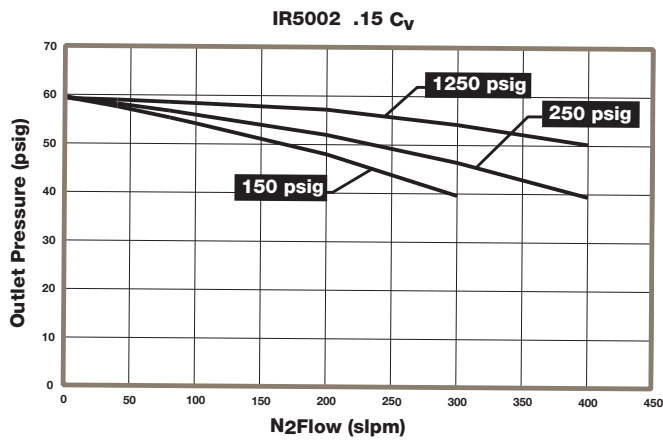
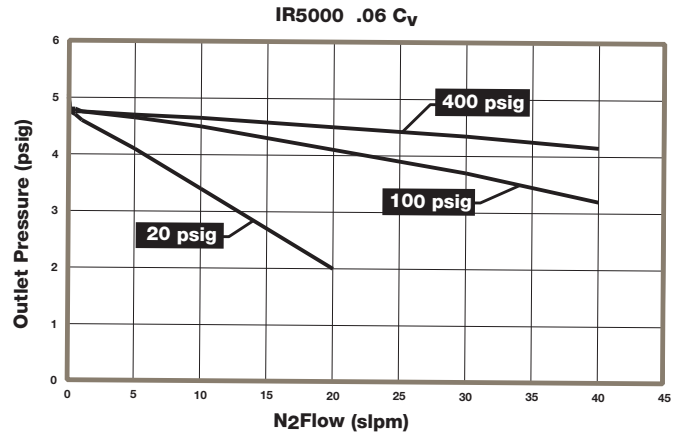
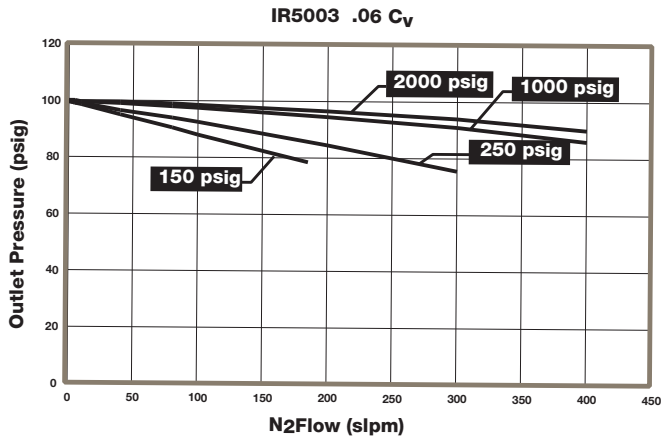

Basic Model	Range Table		
	Maximum Inlet PSIG		
	0.06 Cv	0.02 Cv	0.15 Cv
IR5000	400	400	400
IR5001	3,500	3,500	1,250
IR5002	3,500	3,500	1,250
IR5003	3,500	3,500	1,250
IR5004	3,500	3,500	1,250

## Dimensional Drawing:

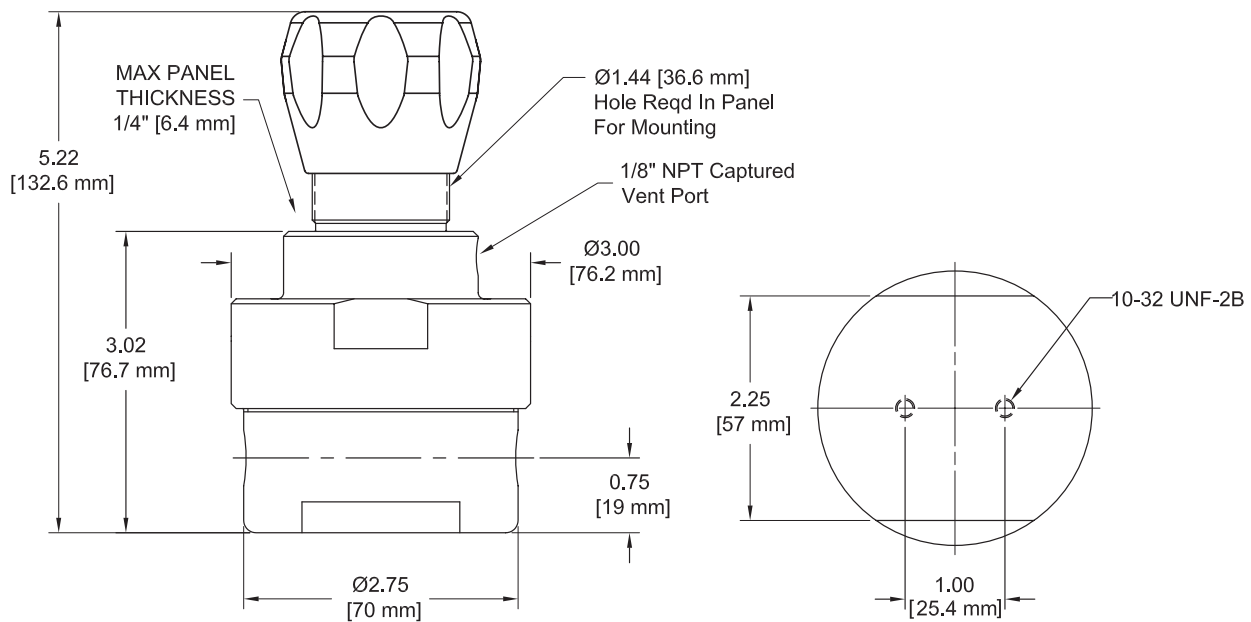

# IR5000 Series

## Ordering Information:

Building a Part Number: *Example: IR5002SK4P01304B*

Example Part Number:	IR50	02	S		K	4P	01	30	4	B	
Ordering Parameters/Options:	Regulator	Basic Series	Body Material	Flow Capacity	Seat Material	Porting	Outlet Gauge	Inlet Gauge	Port Style	Port Mounting	Optional Features
Table Reference: (see below)	A	B	C	D	E	F	G	H	I	J	K

A - Regulator	
IR50	IR5000 Series Regulator

B - Basic Series (Range / Outlet Gauge)	
00	0-5 psig (Note: Maximum inlet pressure is 400 psig)
01	1-30 psig
02	2-60 psig
03	3-100 psig
04	10-250 psig

C - Body Material (1)	
S	316L Stainless Steel (Consult factory for Alloy Material options and availability)

D - Flow Capacity	
	0.06 C <sub>V</sub> (std)
1	0.02 C <sub>V</sub>
2	0.15 C <sub>V</sub>

E - Seat Material	
K	PCTFE
P	PEEK™
V	Vespel® (Recommended for Nitrous Oxide (N <sub>2</sub> O) Service)

F - Porting	
2P	2 Ports (No X required for gauges, inlet and outlet ports only)
3P	3 Ports (One X for gauge ports)
4P	4 Ports (Two X for gauge ports)
4PB	4 Ports (One X for gauge ports)

Note: Ports may be plugged for NPT threaded product.

G - Outlet Gauge / Basic Series	
05	0-15 psig / IR5000
OL	0-60 psig / IR5001
01	0-100 psig / IR5002
2	0-200 psig / IR5003
4	0-400 psig / IR5004
X	No Gauge (Gauges may be provided by local Distributor)

H - Inlet Gauge	
X	No Gauge
30	3,000 psig (std)
4	400 psig (with 10 psig range)
20	2,000 psig with the 0.15 C <sub>V</sub> option
40	4,000 psig

I - Port Style	
4	1/4" NPT Female (All Gauges ports are 1/4" NPT Female)

J - Port Mounting	
B	0.75 (19.1 mm) port height with 1.0 (25.4 mm) mounting (std)

K - Optional Features (This section can have multiple options)	
C	Corrosion Resistant External (Stainless Steel Cap)
G	Tamper Proof (Not available with D or M option)
L	PTFE Back Up O-ring (PCTFE and PEEK™ Seats Only)
M	Metal Knob (Black: Not available with G option, required for temps. above 150° F)
C3	Cleaned for Oxygen Service (Oxygen cleaning requirements are in accordance with Parker Specification ES8003)

**Note:**

**Panel Mount Option:** Order Panel Mount Nut Ring (PN: IR4-Panel-Nut-B-NP) as separate line item

**Vent Muffler Option:** Vent Muffler (PN: Muffler-2F-Bronze) as separate line item.

Vent Muffler is standard for the Corrosion Resistant (C) option.

A gas with low molecular weight, such as Hydrogen and Helium, may cause flow vibration.

**Parker Instrumentation Products Division reserves the right to plug NPT ports**

# Parker Worldwide

## North America

**USA** – Corporate, Cleveland, OH  
Tel: +1 256 896 3000

**USA** – IPD, Huntsville, AL  
Tel: +1 256 881 2040  
ipdcct@parker.com

**USA** – IPD, (Autoclave), Erie, PA  
Tel: +1 814 860 5700  
ipdaect@parker.com

**CA** – Canada, Grimsby, Ontario  
Tel: +1 905-945-2274  
ipd\_canada@parker.com

## South America

**AR** – Argentina, Buenos Aires  
Tel: +54 3327 44 4129  
falecom@parker.com

**BR** – Brazil, Diadema, SP  
Diadema, SP  
Tel: +55 11 4360 6700  
falecom@parker.com

**CL** – Chile, Santiago  
Tel: +56 (0) 2 2303 9640  
falecom@parker.com

**MX** – Mexico, Toluca  
Tel: +52 722 275 4200  
contacto@parker.com

## Asia Pacific

**AU** – Australia, Dandenong  
Tel: +61 (0)2 9842 5150  
customer.service.au@parker.com

**CN** – China, Shanghai  
Tel: +86 21 2899 5000  
INGtechnical.china@parker.com

**HK** – Hong Kong  
Tel: +852 2428 8008

**IN** – India, Mumbai  
Tel: +91 22 6513 7081-85

**ID** – Indonesia, Tangerang  
Tel: +62 2977 7900  
parker.id@parker.com

**JP** – Japan, Tokyo  
Tel: +(81) 3 6365 4020  
infophj@parker.com

**KR** – South Korea, Seoul  
Tel: +82 2 559 0400  
parkerkr@parker.com

**MY** – Malaysia, Selangor  
Tel: +603 784 90 800  
parkermy@parker.com

**SG** – Singapore,  
Tel: +65 6887 6300  
parkerkg@parker.com

**TH** – Thailand, Bangkok  
Tel: +66 2 186 7000  
phthailand@parker.com

**TW** – Taiwan, Taipei  
Tel: +886 2 2298 8987  
enquiry.taiwan@parker.com

**VN** – Vietnam, Hochi Minh City  
Tel: +848 382 508 56  
parker\_viet@parker.com

## Europe, Middle East, Africa

**AE** – UAE, Dubai  
Tel: +971 4 812 7100  
parker.me@parker.com

**AT** – Austria, Wiener Neustadt  
Tel: +43 (0)2622 23501-0  
parker.austria@parker.com

**AT** – Eastern Europe, Wiener Neustadt  
Tel: +43 (0)2622 23501 900  
parker.easteurope@parker.com

**AZ** – Azerbaijan, Baku  
Tel: +994 50 2233 458  
parker.azerbaijan@parker.com

**BE/LU** – Belgium, Nivelles  
Tel: +32 (0)67 280 900  
parker.belgium@parker.com

**BG** – Bulgaria, Sofia  
Tel: +359 2 980 1344  
parker.bulgaria@parker.com

**BY** – Belarus, Minsk  
Tel: +48 (0)22 573 24 00  
parker.belarus@parker.com

**CH** – Switzerland, Etoy  
Tel: +41 (0) 21 821 87 00  
parker.switzerland@parker.com

**CZ** – Czech Republic, Klecany  
Tel: +420 284 083 111  
parker.czechrepublic@parker.com

**DE** – Germany, Kaarst  
Tel: +49 (0)2131 4016 0  
parker.germany@parker.com

**DK** – Denmark, Ballerup  
Tel: +45 43 56 04 00  
parker.denmark@parker.com

**ES** – Spain, Madrid  
Tel: +34 902 33 00 01  
parker.spain@parker.com

**FI** – Finland, Vantaa  
Tel: +358 (0)20 753 2500  
parker.finland@parker.com

**FR** – France, Contamine s/Arve  
Tel: +33 (0)4 50 25 80 25  
parker.france@parker.com

**GR** – Greece, Athens  
Tel: +30 210 933 6450  
parker.greece@parker.com

**HU** – Hungary, Budapest  
Tel: +36 223 885 470  
parker.hungary@parker.com

**IE** – Ireland, Dublin  
Tel: +353 (0)1 466 6370  
parker.ireland@parker.com

**IT** – Italy, Corsico (MI)  
Tel: +39 02 45 19 21  
parker.italy@parker.com

**KZ** – Kazakhstan, Almaty  
Tel: +7 7273 561 000  
parker.easteurope@parker.com

**NL** – The Netherlands, Oldenzaal  
Tel: +31 (0)541 585 000  
parker.nl@parker.com

**NO** – Norway, Stavanger  
Tel: +47 66 75 34 00  
parker.norway@parker.com

**PL** – Poland, Warsaw  
Tel: +48 (0)22 573 24 00  
parker.poland@parker.com

**PT** – Portugal, Leca da Palmeira  
Tel: +351 22 999 7360  
parker.portugal@parker.com

**RO** – Romania, Bucharest  
Tel: +40 21 252 1382  
parker.romania@parker.com

**RU** – Russia, Moscow  
Tel: +7 495 645-2156  
parker.russia@parker.com

**SE** – Sweden, Spånga  
Tel: +46 (0)8 59 79 50 00  
parker.sweden@parker.com

**SK** – Slovakia, Banská Bystrica  
Tel: +421 484 162 252  
parker.slovakia@parker.com

**SL** – Slovenia, Novo Mesto  
Tel: +386 7 337 6650  
parker.slovenia@parker.com

**TR** – Turkey, Istanbul  
Tel: +90 216 4997081  
parker.turkey@parker.com

**UA** – Ukraine, Kiev  
Tel: +48 (0)22 573 24 00  
parker.ukraine@parker.com

**UK** – United Kingdom, Warwick  
Tel: +44 (0)1926 317 878  
parker.uk@parker.com

**ZA** – South Africa, Kempton Park  
Tel: +27 (0)11 961 0700  
parker.southafrica@parker.com

## WARNING

**FAILURE, IMPROPER SELECTION OR IMPROPER USE OF THE PRODUCTS AND/OR SYSTEMS DESCRIBED HEREIN OR RELATED ITEMS CAN CAUSE DEATH, PERSONAL INJURY AND PROPERTY DAMAGE.**

This document and other information from Parker Hannifin Corporation, its subsidiaries and authorized distributors provide product and/or system options for further investigation by users having technical expertise. It is important that you analyze all aspects of your application and review the information concerning the product or system in the current product catalog. Due to the variety of operating conditions and applications for these products or systems, the user, through its own analysis and testing, is solely responsible for making the final selection of the products and systems and assuring that all performance, safety and warning requirements of the application are met. The products described herein, including without limitation, product features, specifications, designs, availability and pricing, are subject to change by Parker Hannifin Corporation and its subsidiaries at any time without notice. Proposition 65 Warning: This product contains chemicals known to the state of California to cause cancer or birth defects or other reproductive harm.

## Offer of Sale

The items described in this document are available for sale by Parker Hannifin Corporation, its subsidiaries or its authorized distributors. Any sale contract entered by Parker will be governed by the provisions stated in Parker's standard terms and conditions of sale (copy available upon request).

©2018 Parker Hannifin Corporation | Instrumentation Products Division

Literature #: **25000127** June 2018



Instrumentation Products Division  
1005 A Cleaner Way  
Huntsville, AL 35805 • USA  
Tel: 256 881 2040  
Fax: 256 881 5072

ipd.sales@parker.com  
[www.parker.com/ipd](http://www.parker.com/ipd)  
Mobile Application: [m.parker.com/ipd](http://m.parker.com/ipd)

**IR5000 SERIES: Single Stage, High Sensitivity Pressure Regulator**



**ENGINEERING YOUR SUCCESS.**