

Hi-Pro Ball Valve for High Performance Process Isolation

Catalog 4190-HBV

aerospace
climate control
electromechanical
filtration
fluid & gas handling
hydraulics
pneumatics
process control
sealing & shielding



ENGINEERING YOUR SUCCESS.

Product Description

These high performance two piece bi-directional Ball Valves offer the user full cold working pressure ratings up to 10,000 psi (689 bar), giving 100% bubble tight shut off and continuous repeatable performance. The Ball Valves are suitable for the most demanding applications in the oil, gas and process control industries. All valves also meet the requirements of ANSI B31.1 for use in power plants.

By offering a true two piece design, body leakage paths are reduced to a minimum. With the added opportunity to select integral compression ends the user can eliminate the use of taper threads and thread sealant. This avoids system contamination, reduces leakage paths, installation costs, weight and space.

Specifications

- 316 Stainless steel construction
- Maximum cold working pressure rating 6,000 psi (414 bar) with P.T.F.E. seats*
- Temperature rating PTFE seats -54°C to +204°C (-65°F to +400°F) *
- Maximum cold working pressure rating 10,000 psi (689 bar) with PEEK seats†
- Temperature rating PEEK seats -54°C to +232°C (-65°F to +450°F) *
- Cv values - 10mm, 15mm, 20mm and 25mm

* Always refer to P/T graph

† All B31.1 compliant valves are limited to a maximum working pressure of 6000psi (414 bar)

Features

- Two piece body design - minimal leakage paths
- 4:1 Pressure boundary designed safety factor
- Designed to comply with requirements of ANSI/ASME B16.34 where applicable
- Bi-directional
- PEEK and PTFE standard ball seat materials
- PHflex seats available for 25mm bore
- PTFE and Graphoil gland packings
- Bubble tight shutoff
- Floating ball principal with dynamic response seats featuring inherent self relief
- Anti blowout stem
- Integral compression ends available eliminating taper threads and thread sealants
- Low torque operation
- Quarter turn positive stop handle with ergonomically designed protective sleeve
- Full hydrostatic and low pressure air tested
- Connector thread environmentally sealed
- Anti static
- Firesafe designed to meet API 607, BS6755 Pt2 (optional)

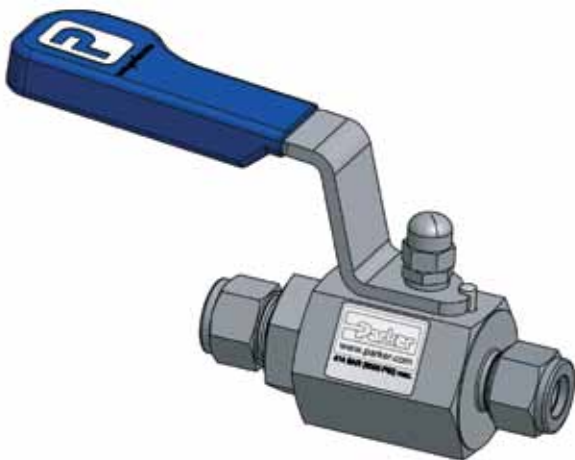

WARNING

FAILURE, IMPROPER SELECTION OR IMPROPER USE OF THE PRODUCTS AND/OR SYSTEMS DESCRIBED HEREIN OR RELATED ITEMS CAN CAUSE DEATH, PERSONAL INJURY AND PROPERTY DAMAGE.

This document and other information from Parker Hannifin Corporation, its subsidiaries and authorized distributors provide product and/or system options for further investigation by users having technical expertise. It is important that you analyze all aspects of your application and review the information concerning the product or system in the current product catalog. Due to the variety of operating conditions and applications for these products or systems, the user, through its own analysis and testing, is solely responsible for making the final selection of the products and systems and assuring that all performance, safety and warning requirements of the application are met.

The products described herein, including without limitation, product features, specifications, designs, availability and pricing, are subject to change by Parker Hannifin Corporation and its subsidiaries at any time without notice.

Offer of Sale

The items described in this document are hereby offered for sale by Parker Hannifin Corporation, its subsidiaries or its authorized distributors. Any Order accepted by Parker Hannifin will be subject to our terms and conditions of sale, copy available on request.

for up to Class 4500 (10,000 psi/689 bar) operations (10mm bore)

Hi-Pro Ball Valve

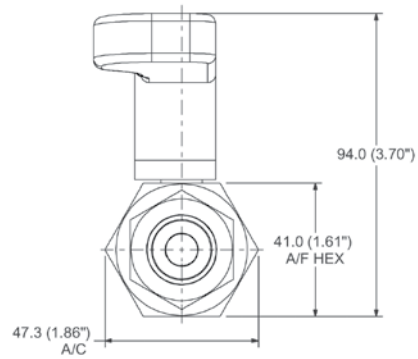
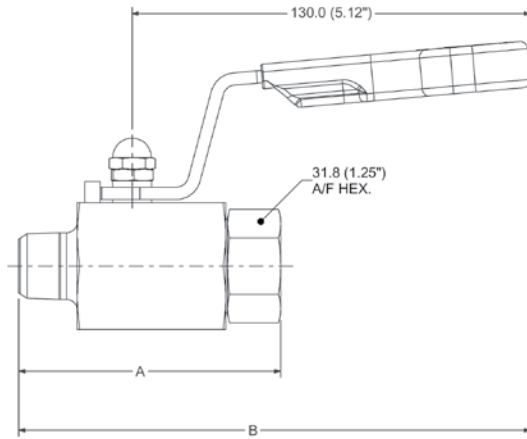

Standard range part numbers 10mm bore

Part number	Part number	Inlet	Outlet	Dimensions	
Class 2500	Class 4500	Female	Female	A mm (inch)	B mm (inch)
HPBY*4FF	HPBY*4FFHP	1/4" Female	1/4" Female	70.0 (2.76)	161.5 (6.36)
HPBY*6FF	HPBY*6FFHP	3/8" Female	3/8" Female	71.0 (2.80)	162.0 (6.38)
HPBY*8FF	HPBY*8FFHP	1/2" Female	1/2" Female	85.0 (3.35)	166.5 (6.56)
		Male	Female		
HPBY*4M4F	HPBY*4M4FHP	1/4" Male	1/4" Female	70.0 (2.76)	161.5 (6.36)
HPBY*8M8F	HPBY*8M8FHP	1/2" Male	1/2" Female	85.0 (3.35)	166.5 (6.56)
		A-LOK®	A-LOK®		
HPBY*4A	—	1/4" A-LOK®	1/4" A-LOK®	95.0 (3.74)	165.5 (6.52)
HPBY*6A	—	3/8" A-LOK®	3/8" A-LOK®	99.1 (3.90)	167.4 (6.59)
HPBY*8A	—	1/2" A-LOK®	1/2" A-LOK®	104.7 (4.12)	170.2 (6.70)
HPBY*M6A	—	6mm A-LOK®	6mm A-LOK®	95.0 (3.74)	165.5 (6.52)
HPBY*M8A	—	8mm A-LOK®	8mm A-LOK®	96.6 (3.80)	166.3 (6.55)
HPBY*M10A	—	10mm A-LOK®	10mm A-LOK®	99.5 (3.92)	167.6 (6.60)
HPBY*M12A	—	12mm A-LOK®	12mm A-LOK®	104.7 (4.12)	170.2 (6.70)

*Insert material code - select from material matrix (B = Standard 316 Stainless Steel). For CPI™ change A to Z. "A" dimensions given for finger tight nuts. For compression ended valve pressure ratings consult tube ratings table. Combination ends are available.

Standard product specification: PTFE packing with PTFE seats, 10mm bore ball 6,000 psi (414 bar).

Standard product specification: PTFE packing with PEEK seats, 10mm bore ball 10,000 psi (689 bar).

Cold working pressures (psi/bar) in accordance with ANSI/ASME B16.34

Class Rating				
Material	*Insert	1500	2500	4500
316 Stainless steel std	B	3600/248	6000/414	10000/689
Alloy 400	D		5000/345	9000/620
Duplex	E	3600/248	6000/414	10000/689
Super Duplex	F		6000/414	10000/689
Hasteloy	G		6000/414	10000/689
6Mo	K		6000/414	10000/689
Alloy 625	M		6000/414	10000/689

Available options	Part number Suffix
Graphoil packing	3
PEEK seats	PK
Secured end connector	LC
Handle locking	HL
Spanner actuation	SA
Panel mounting	PM
Fire safe design - Graphoil packing (std)	FS
NACE compliant materials**	NC
Retro-fit handle locking kit (for site assembly)	HPHLKIT
PHlex seats	PH
Base mounting holes (consult Parker)	-

Note: Heat Code Trace (HCT) material traceability certificates available on request **Does not apply for A-lok/CPI ended valves in 316 stainless steel.

Hi-Pro Ball Valve

for up to Class 4500 (10,000 psi/689 bar) operations (15mm bore)

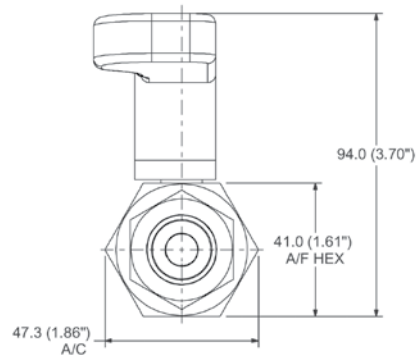
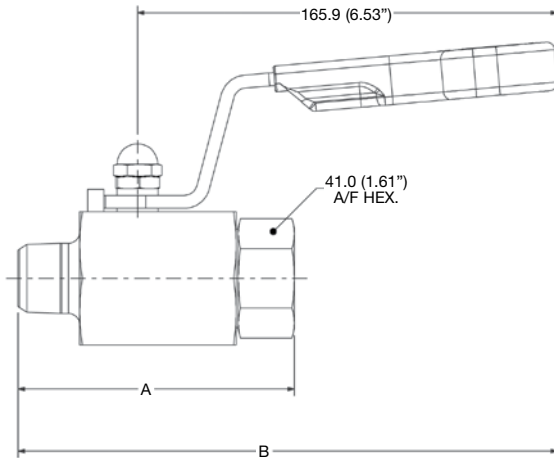

Standard range part numbers 15mm bore

Part number	Part number	Inlet	Outlet	Dimensions	
Class 2500	Class 4500	Female	Female	A mm (inch)	B mm (inch)
HPBX*8FF	HPBX*8FFHP	1/2" Female	1/2" Female	97.2 (3.83)	207.9 (8.18)
		Male	Female		
HPBX*8M8F	HPBX*8M8FHP	1/2" Male	1/2" Female	102.9 (4.05)	213.6 (8.41)
		A-LOK®	A-LOK®		
HPBX*10A	—	5/8" A-LOK®	5/8" A-LOK®	118.0 (4.65)	212.6 (8.37)
HPBX*12A	—	3/4" A-LOK®	3/4" A-LOK®	121.9 (4.80)	214.6 (8.45)
HPBX*M16A	—	16mm A-LOK®	16mm A-LOK®	120.0 (4.72)	214.2 (8.43)
HPBX*M18A	—	18mm A-LOK®	18mm A-LOK®	120.0 (4.72)	214.2 (8.43)
HPBX*M20A	—	20mm A-LOK®	20mm A-LOK®	120.0 (4.72)	214.2 (8.43)

*Insert material code - select from material matrix (B = Standard 316 Stainless Steel). For CPI™ change A to Z. "A" dimensions given for finger tight nuts. For compression ended valve pressure ratings consult tube ratings table. Combination ends are available.

Standard product specification: PTFE packing with PTFE seats, 15mm bore ball 6,000 psi (414 bar).

Standard product specification: PTFE packing with PEEK seats, 15mm bore ball 10,000 psi (689 bar).

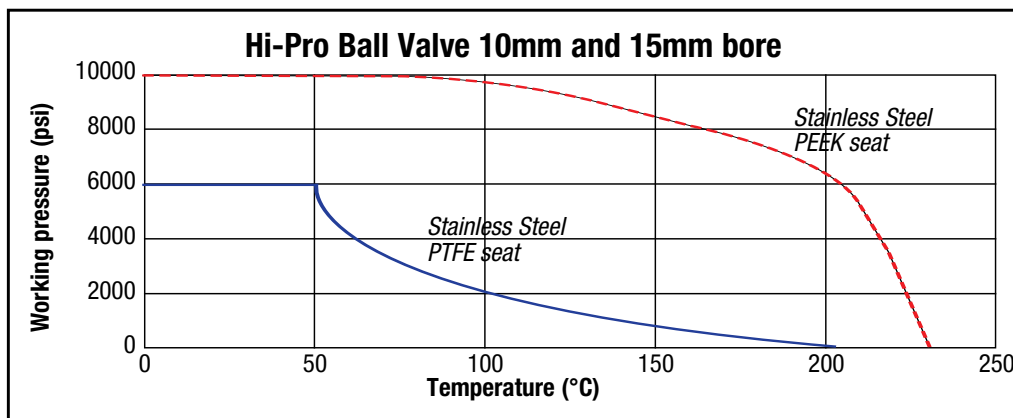

Materials and options as per page 3

for up to Class 2500 (6,000 psi/414 bar)
operations (20 & 25mm bore)

Hi-Pro Ball Valve

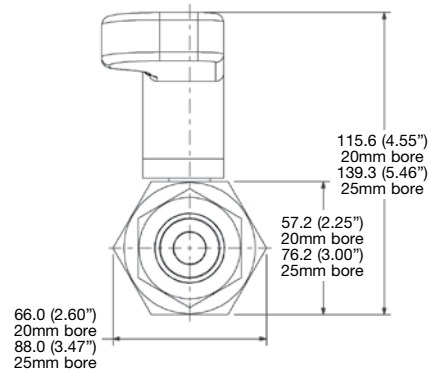
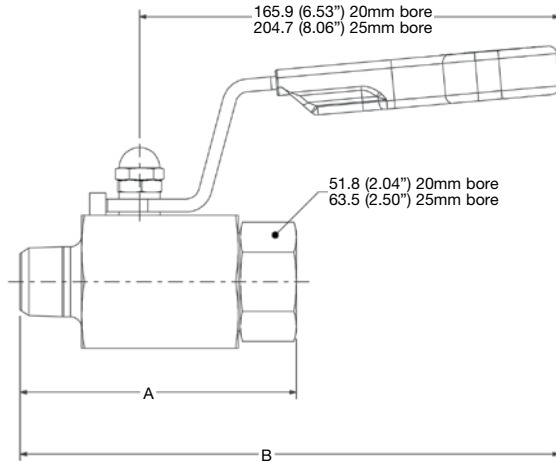

Standard range part numbers 20mm bore

Part number	Part number	Inlet	Outlet	Dimensions	
Class 1500	Class 2500	NPT	NPT	A mm (inch)	B mm (inch)
HPBW*12FFLP	HPBW*12FF	3/4" Female	3/4" Female	89.8 (3.54)	204.1 (8.03)
HPBW*12M12FLP	HPBW*12M12F	3/4" Male	3/4" Female	102.5 (4.04)	216.8 (8.53)
		A-LOK®	A-LOK®		
HPBW*14ALP	—	7/8" A-LOK®	7/8" A-LOK®	134.0 (5.28)	221.1 (8.71)
HPBW*16ALP	—	1" A-LOK®	1" A-LOK®	137.6 (5.42)	222.9 (8.77)
HPBW*M22ALP	—	22mm A-LOK®	22mm A-LOK®	133.3 (5.25)	220.8 (8.69)
HPBW*M25ALP	—	25mm A-LOK®	25mm A-LOK®	137.1 (5.40)	222.7 (8.77)

*Insert material code - select from material matrix (B = Standard 316 Stainless Steel). For CPI™ change A to Z. "A" dimensions given for finger tight nuts. For compression ended valve pressure ratings consult tube ratings table. Combination ends are available.

Standard product specification: PTFE packing with PTFE seats, 20mm bore ball 3,600 psi (247 bar).

Standard product specification: PTFE packing with PEEK seats, 20mm bore ball 6,000 psi (414 bar).

Standard range part numbers 25mm bore

Part number	Part number	Inlet	Outlet	Dimensions	
Class 1500	Class 2500	NPT	NPT	A mm (inch)	B mm (inch)
HPBV*16FFLP	HPBV*16FF	1" Female	1" Female	128.4 (5.05)	260.3 (10.23)
HPBV*16M16FLP	HPBV*16M16F	1" Male	1" Female	132.2 (5.20)	264.1 (10.40)
		A-LOK®	A-LOK®		
HPBV*16ALP	—	1" A-LOK®	1" A-LOK®	153.2 (6.03)	269.8 (10.62)
HPBV*M25ALP	—	25mm A-LOK®	25mm A-LOK®	153.2 (6.03)	269.8 (10.62)

*Insert material code - select from material matrix (B = Standard 316 Stainless Steel). For CPI™ change A to Z. "A" dimensions given for finger tight nuts. For compression ended valve pressure ratings consult tube ratings table. Combination ends are available.

Standard product specification: PTFE packing with PTFE or PEEK seats, 25mm bore ball 3,600 psi (247 bar).

PTFE packing with PHflex seats, 25mm bore ball 6,000 psi (414 bar).

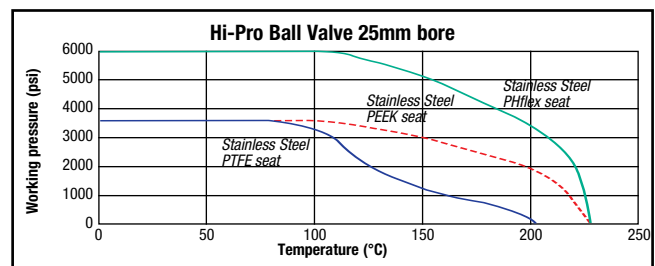
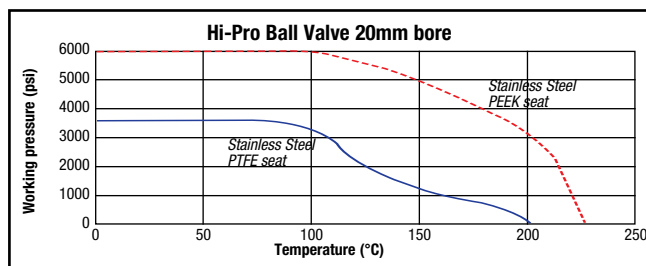

Materials and options as per page 3

Hi-Pro Multi Port Gauge Valve

for up to Class 4500 (10,000 psi/ 689 bar) operations (10mm bore)

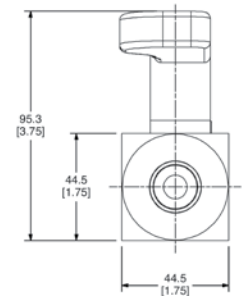
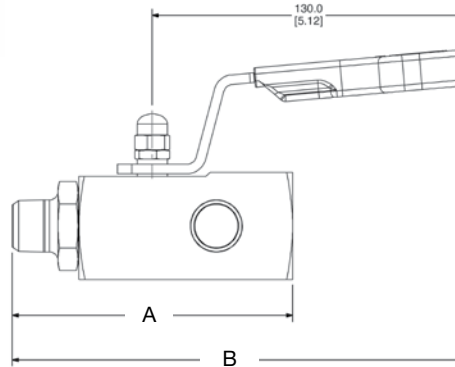
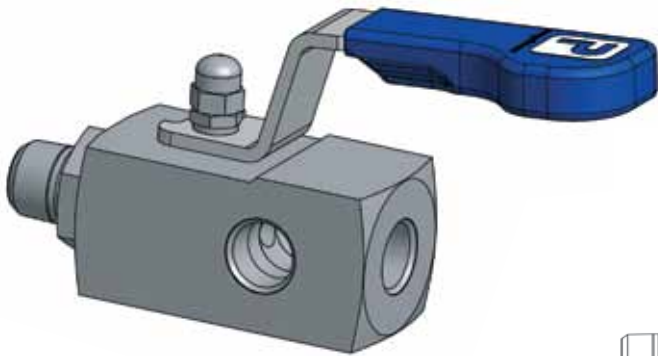

Standard Product Specifications

Part No. HPBYGVB8: 316 Stainless Steel construction, PTFE packing, PTFE seats, 10mm bore ball, 6,000 psi (414 bar), 1/2" NPT male inlet x 3 – 1/2" NPT female outlets.

Part No. HPBYGVB12: 316 Stainless Steel construction, PTFE packing, PTFE seats, 10mm bore ball, 6,000 psi (414 bar), 3/4" NPT male inlet x 3 – 1/2" NPT female outlets.

Part No. HPBYGVB8HP: 316 Stainless Steel construction, PTFE packing, PEEK seats, 10mm bore ball, 10,000 psi (689 bar), 1/2" NPT male inlet x 3 – 1/2" NPT female outlets.

Part No. HPBYGVB12HP: 316 Stainless Steel construction, PTFE packing, PEEK seats, 10mm bore ball, 10,000 psi (689 bar), 3/4" NPT male inlet x 3 – 1/2" NPT female outlets.

Note: To obtain optional bleed valve and/or blank plug with the gauge valve the above part number must be suffixed accordingly. If these parts are required they will be shipped loose in the box for customer assembly using their preferred thread sealant.

Part number	Part number	Inlet	Outlet	Dimensions	
6000 psi (414 bar)	10000 psi (689 bar)	Male	Female	A mm (inch)	B mm (inch)
HPBYGV*8	HPBYGV*8HP	1/2" NPT	3x1/2" NPT	116.5 (4.59)	188.1 (7.41)
HPBYGV*12	HPBYGV*12HP	3/4" NPT	3x1/2" NPT	119.5 (4.71)	191.1 (7.52)

*Insert material code - select from material matrix (B = Standard 316 Stainless Steel).



Bleed valve



Plug

Materials and options as per page 3

for up to Class 4500 (10,000 psi/
689 bar) operations

Hi-Pro Ball Valve

Part description

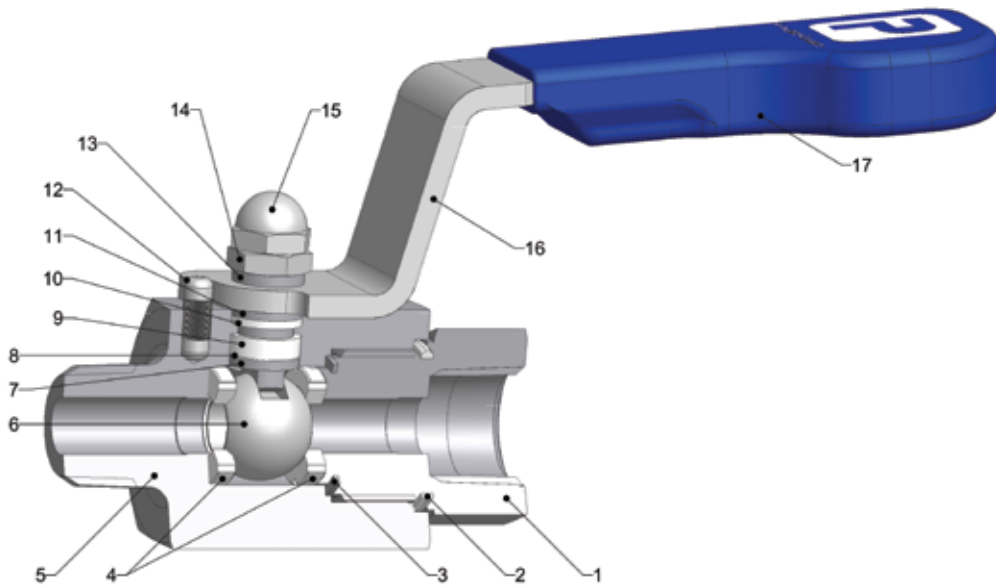

Item	Description
1	End Connector
2	E-seal™
3	Sealing washer
4	Seats
5	Body
6	Ball
7	Anti blowout stem
8	Thrust Seal
9	Gland packing
10	Upper gland packing
11	Thrust bush
12	Stop pin
13	Thrust bush
14	Lock nut
15	Locking dome nut
16	Handle
17	Handle grip



Handle locking
(padlock not supplied)



Secured end connector
(double pin)

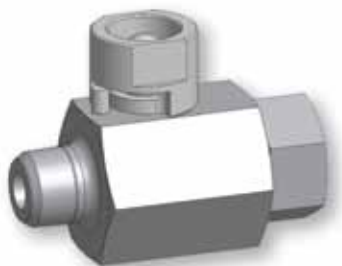

Spanner actuation



Panel mounting
(c/w nuts & bolts)

Parker Worldwide

AE – UAE, Dubai
Tel: +971 4 8875600
parker.me@parker.com

AR – Argentina, Buenos Aires
Tel: +54 3327 44 4129

AT – Austria, Wiener Neustadt
Tel: +43 (0)2622 23501-0
parker.austria@parker.com

AT – Eastern Europe, Wiener Neustadt
Tel: +43 (0)2622 23501 970
parker.easteurope@parker.com

AU – Australia, Castle Hill
Tel: +61 (0)2-9634 7777

AZ – Azerbaijan, Baku
Tel: +994 50 2233 458
parker.azerbaijan@parker.com

BE/LX – Belgium, Nivelles
Tel: +32 (0)67 280 900
parker.belgium@parker.com

BR – Brazil, Cachoeirinha RS
Tel: +55 51 3470 9144

BY – Belarus, Minsk
Tel: +375 17 209 9399
parker.belarus@parker.com

CA – Canada, Milton, Ontario
Tel: +1 905 693 3000

CH – Switzerland, Etoy
Tel: +41 (0) 21 821 02 30
parker.switzerland@parker.com

CN – China, Shanghai
Tel: +86 21 5031 2525

CZ – Czech Republic, Klecany
Tel: +420 284 083 111
parker.czechrepublic@parker.com

DE – Germany, Kaarst
Tel: +49 (0)2131 4016 0
parker.germany@parker.com

DK – Denmark, Ballerup
Tel: +45 43 56 04 00
parker.denmark@parker.com

ES – Spain, Madrid
Tel: +34 902 33 00 01
parker.spain@parker.com

FI – Finland, Vantaa
Tel: +358 (0)20 753 2500
parker.finland@parker.com

FR – France, Contamine s/Arve
Tel: +33 (0)4 50 25 80 25
parker.france@parker.com

GR – Greece, Athens
Tel: +30 210 933 6450
parker.greece@parker.com

HK – Hong Kong
Tel: +852 2428 8008

HU – Hungary, Budapest
Tel: +36 1 220 4155
parker.hungary@parker.com

IE – Ireland, Dublin
Tel: +353 (0)1 466 6370
parker.ireland@parker.com

IN – India, Mumbai
Tel: +91 22 6513 7081-85

IT – Italy, Corsico (MI)
Tel: +39 02 45 19 21
parker.italy@parker.com

JP – Japan, Fujisawa
Tel: +(81) 4 6635 3050

KR – South Korea, Seoul
Tel: +82 2 559 0400

KZ – Kazakhstan, Almaty
Tel: +7 7272 505 800
parker.easteurope@parker.com

LV – Latvia, Riga
Tel: +371 6 745 2601
parker.latvia@parker.com

MX – Mexico, Apodaca
Tel: +52 81 8156 6000

MY – Malaysia, Shah Alam
Tel: +603-78490800

NL – The Netherlands, Oldenzaal
Tel: +31 (0)541 585 000
parker.nl@parker.com

NO – Norway, Stavanger
Tel: +47 (0)51 826 300
parker.norway@parker.com

NZ – New Zealand, Mt Wellington
Tel: +64 9 574 1744

PL – Poland, Warsaw
Tel: +48 (0)22 573 24 00
parker.poland@parker.com

PT – Portugal, Leca da Palmeira
Tel: +351 22 999 7360
parker.portugal@parker.com

RO – Romania, Bucharest
Tel: +40 21 252 1382
parker.romania@parker.com

RU – Russia, Moscow
Tel: +7 495 645-2156
parker.russia@parker.com

SE – Sweden, Spånga
Tel: +46 (0)8 59 79 50 00
parker.sweden@parker.com

SG – Singapore,
Tel: +65 6887 6300

SK – Slovakia, Banská Bystrica
Tel: +421 484 162 252
parker.slovakia@parker.com

SL – Slovenia, Novo Mesto
Tel: +386 7 337 6650
parker.slovenia@parker.com

TH – Thailand, Bangkok
Tel: +662 717 8140

TR – Turkey, Istanbul
Tel: +90 216 4997081
parker.turkey@parker.com

TW – Taiwan, Taipei
Tel: +886 2 2298 8987

UA – Ukraine, Kiev
Tel: +380 44 494 2731
parker.ukraine@parker.com

UK – United Kingdom, Barnstaple
Tel: +44 (0)1271 313131
parker.uk@parker.com

US – USA, Cleveland
Tel: +1 216 896 3000

VE – Venezuela, Caracas
Tel: +58 212 238 5422

ZA – South Africa, Kempton Park
Tel: +27 (0)11 961 0700
parker.southafrica@parker.com

European Product Information Centre
Free phone: 00 800 27 27 5374
(from AT, BE, CH, CZ, DE, DK, EE, EI, ES, FI,
FR, IT, NL, NO, PL, RU, SE, SK, UK, ZA)

© 2008 Parker Hannifin Corporation. All rights reserved



Parker Hannifin Ltd
**Instrumentation Products
Division Europe,**
Riverside Road,
Pottington Business Park,
Barnstaple, Devon, EX31 1NP
United Kingdom
Tel.: +44 (0) 1271 313131
Fax: +44 (0) 1271 373636
www.parker.com/ipd

Parker Hannifin Corporation
Instrumentation Products Division
1005 A Cleaner Way
Huntsville, AL 35805
Tel: + 1 (256) 881-2040
Fax: + 1 (256) 881-5072
www.parker.com/ipdus

Catalogue 4190-HBV